

2017 SDSMT Clean Snowmobile Design Overview

Kurt Mentele & Trevor Gunderson

Copyright © 2017 SAE International

Abstract

The 2017 South Dakota School of Mines and Technology is working on an updated electric snowmobile concept for competition in the Society of Automotive Engineers Clean Snowmobile Challenge. Goals for the 2017 build are to improve all-around performance over the 2017 SDSMT electric snowmobile. Emphasis was placed on vehicle weight, drivetrain simplicity, ergonomics, and overall efficiency. By focusing on these goals, the team works to produce a snowmobile that is comparable in performance to its gasoline equivalent. The result is a machine that meets the premise of the competition as a research vehicle, but also leads the way into producing a snowmobile that could be offered to consumers for recreational applications.

Introduction

The South Dakota School of Mines and Technology places an emphasis on developing new technologies, as well as sustainable energy and resources. One of the projects that focuses on this objective is the Alternative Fuel Vehicle – Electric Snowmobile Team. The team competes annually at the SAE Clean Snowmobile Challenge in the Zero Emissions category. The purpose of this document is to describe the project overview and design concept of the snowmobile. By describing the project

overview, discussing major mechanical systems, electrical systems, performance, ergonomics, and cost, the challenges of developing an electric snowmobile can be understood. Using performance and design goals defined by the SDSMT electric snowmobile team as a reference, the design outline in this document will help to prove why the SDSMT electric snowmobile is able to compete at a high level with internal combustion snowmobiles.

Project Overview

The SDSMT Electric Snowmobile Team has been a student organization since 2007 and has since worked to develop more advanced machines to compete in the SAE challenge. Students from civil, electrical, and mechanical engineering, along with physics majors work together to build the machine. The team has set new goals to improve upon 2016-2017 design concepts. These goals include: developing a lightweight machine, improved performance and capability, a simplistic electrical drive system, and maintaining the maximum amount of energy allowed by the SAE ZE 2017 rules (8 KWh). Most of these goals have either been achieved, or are in progress as the build comes to a close before the 2017 competition.

Mechanical Design Concept

Chassis

The 2016-2017 SDSMT clean snowmobile is built on a 2014 Polaris Switchback Assault. The team chose this platform for several reasons. With a 144x15x1.325-inch track and tipped up rails, the chassis provides sure-footed performance in both packed-snow conditions and deep-snow conditions, meeting the team's goal for improved performance by providing all around capability and versatility. The chassis and internal combustion engine are lightweight, weighing in at a total of 460 lb (209 Kg) [2] which helps the team meet performance goals.

The chassis features high-performance Walker-Evans piggyback shocks on both the front and rear suspension. These shocks are stiffness adjustable for any style of riding in any condition. They are well suited for the electric applications because they can be stiffened to compensate for the added weight and rearranged weight distributions caused by adding a high-energy battery pack. They will also withstand the abuse sustained during testing of the machine.

The 144-inch track on the 2014 chassis is longer and has more tunnel length than the 136-inch track used on the previous chassis, providing more space for mounting key components, such as the tractive system battery.



Figure 1: 2014 Polaris Switchback Assault used as the platform for the SDSMT electric snowmobile team.

Mechanical Structures

Only one major chassis modification had to be made in order to implement the electrical drive system. This modification involved removing a cast aluminum longitudinal chassis support on the clutch side of a conventional snowmobile, and replacing it with a 100 KSI yield strength steel alloy. This part provides a mounting point for the motor, motor controller, and the enclosure surrounding those components as seen in Figure 2.



Figure 2: Structural modifications support both the electric motor and battery container.

The steel support fits directly into the location of the cast aluminum part, sharing bolt locations. Fastening hardware consists of Grade 8 steel bolts. The support absorbs a small amount of torque from the motor, but is subject to higher compression loads transmitted from the suspension into the chassis. A SolidWorks stress analysis was performed on the part to simulate approximately a 10g chassis load being placed on the part. The results showed that maximum induced stress was approximately 2300psi on the bolt holes. The maximum deflection is 0.00019 inches, and the minimum factor of safety is 18.4. The image exaggeration of deflection can be seen in Figure 3 below.

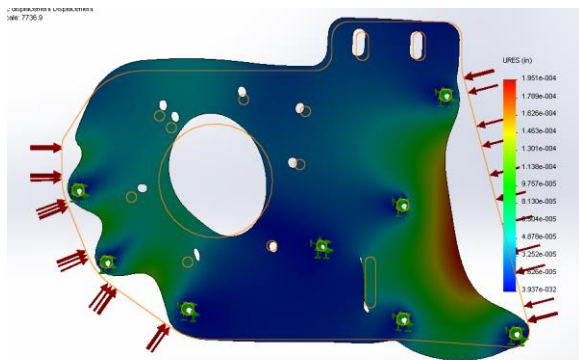

Figure 3: SolidWorks exaggeration of displacement of the structure.

The part was designed by the mechanical engineers on the team, and was manufactured to spec by Trail King Industries in Mitchell, South Dakota using the same process used to manufacture custom application transport trailers. The cost of manufacturing the steel part is comparable to the casting of the aluminum part. The added steel structure helps ensure chassis rigidity and durability.

The next major mechanical structure in the snowmobile is the tractive system battery container. This container must house the six primary batteries, high voltage circuitry, as well as battery control systems. It must also provide a water resistant barrier.

The container is made of 5053 H32 Aluminum sheeting. The sheeting was cut with a water jet at SDSMT to meet design specifications, and was TIG welded together. To make assembly easier and ensure fit and quality, a slot-and-tab design was used. Individual pieces can be fit together like a puzzle, and then welded into place.



Figure 4: The aluminum battery container houses 6 batteries, and is located on the top of the tunnel.

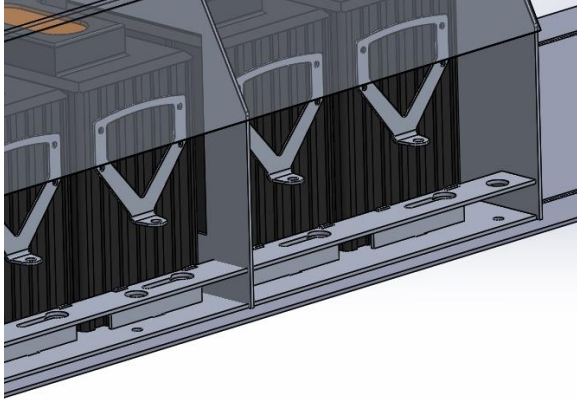

Figure 5: Slots and tabs are used for easy assembly and welding.

The battery box is lined with Formex paper which serves as an electrically insulating barrier between the electrical equipment and the aluminum sidewalls. The battery box container is bolted in six different locations in the slots on the top of the tunnel. Tubular aluminum supports and structural features such as fillets and smooth curves help to ensure the box will meet required loading standard of 10g acceleration in the vertical plane and 20g acceleration in the horizontal plane as stated in the SAE ZE 2017 rules. These features also help make the container easier to manufacture, reducing overall cost while increasing integrity.

Additionally, the battery box acts as the seat of the snowmobile as shown in figure 6. Ergonomics will be discussed later in this document.



Figure 6: The battery box also serves as the seat of the snowmobile.

Other significant mechanical features include a liquid cooling system to cool the motor and the motor controller, the housing and mounting of the motor and motor controller, as well as the support structures for the low voltage system.

Using the heat exchangers that exist on the chassis, cooling components are added such that high power components can be cooled. Specifically, the motor and the high current motor controller are liquid cooled. The motor is manufactured with an internal cooling jacket and requires no modifications to add cooling. SDSM&T designed and manufactured a cooling plate for the motor controller. The plate can be seen in Figure 7.

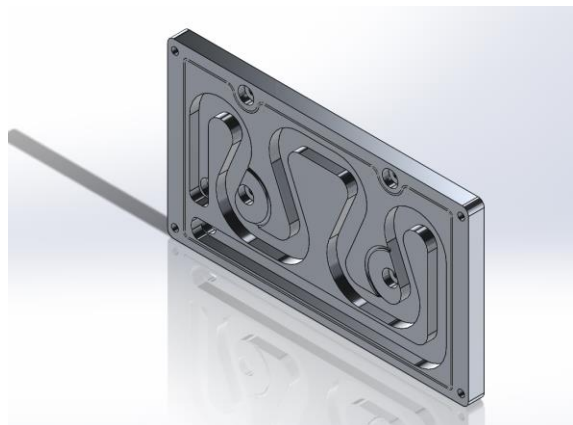

Figure 7: Solidworks drawing of liquid

cooling plate for motor controller.

Another critical structure includes the housing and mounting for the motor and motor controller. This uses an aluminum sleeve that supports the motor as well as the enclosure around the motor and controller assembly. The sleeve is hard bolted to the steel motor plate described previously. The controller uses rubber isolation mounts to reduce vibrations as well as capacitance to the chassis of the snowmobile. This can be seen in Figure 8.

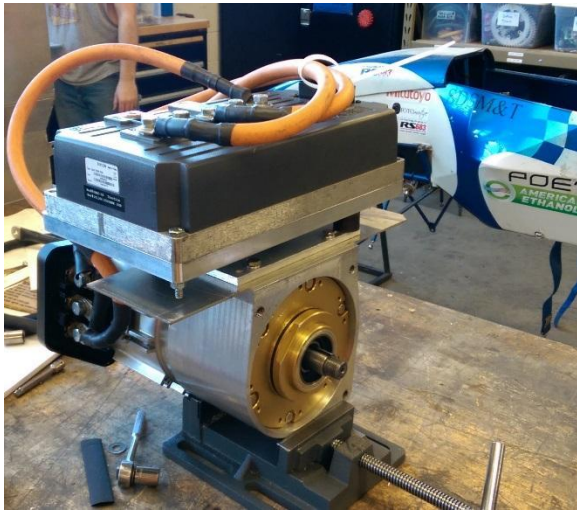

Figure 8: Motor and controller assembly.

After several hundred miles of testing on the snowmobile, the team decided to analyze gear ratio of the belt drive to find a ratio that helped to improve motor efficiency while also helping to increase the top speed and performance of the vehicle. The plot below shows the vehicle speed versus the speed of the motor in RPM. This plot was then compared with the plot of motor torque vs. efficiency in the motor section of this document.

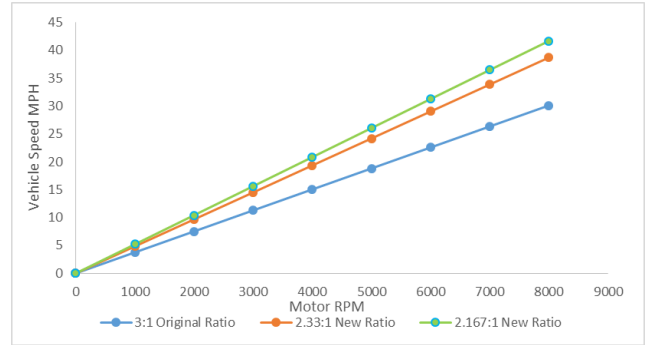

Figure 10: Plot shows the relation between motor speed and rpm with various belt ratios.

The range event of the competition has a pace of around 20mph. The team wanted the peak efficiency of the motor to be around the 20mph point. The blue line (3:1 Ratio) was the ratio originally used on the snowmobile. Although this was good for torque, it limited top speed and let the motor run at about 6000 RPM at 20mph, far past the efficiency range of the motor. This also limited top speed to only 30mph at the 8000 RPM redline of the motor.

The 2.33:1 ratio puts the motor at just over 4000 RPM at 20mph, right at the end of the peak efficiency range for the motor. This also moves the top speed of the snowmobile to a much more trail suited 40mph.

Changing the gear ratio also allowed the team to remove a 25-pound solid steel pulley with a 3-pound aluminum pulley, saving a considerable amount of weight. Figure 11 shows the new pulley on the snowmobile and Figure 12 shows a SolidWorks stress analysis on the pulley with a 160lb**ft* torque placed on it. This resulted in a maximum induced stress of 1782psi. The yield strength of the 7075-T6

Aluminum is 73,244 psi, resulting in a factor of safety of 41, allowing for any variations in torque or any harsh inputs to the belt drive from bumps, jumps, or hard braking.



Figure 11: Belt drive with new aluminum gear.

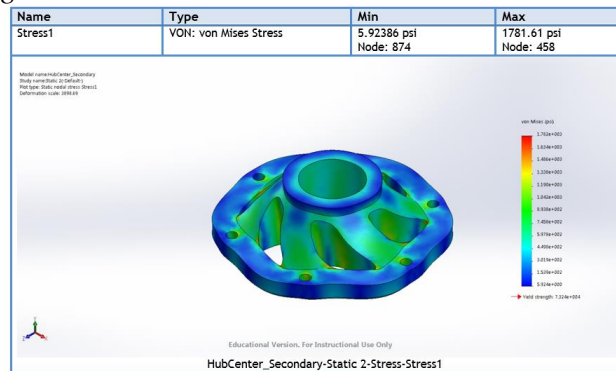

Figure 12: Stress analysis on pulley-center.

Electrical Design Concept

Overview

Designing and building the electrical system presents the biggest challenge of building the electric snowmobile. The system must be sufficiently powerful to move the snowmobile with enthusiasm, but must remain safe and reliable for both novice and experienced riders. The system is at the power limit described by the ZE 2017 rules at 8KWh. The primary tractive battery system is 88.8 volts and 90 amp hours. The

high voltage drives a DC-AC motor controller/inverter which powers a synchronous permanent magnet motor. The high voltage system and protection devices such as the battery management system and insulation monitoring device are powered-on using a low voltage system. Specific components and their performance and functionality characteristics are described below.

Tractive Batteries

The primary tractive battery system consists of six Brammo 15/90 lithium-ion battery modules. Each module is 14.8 volts nominal voltage and 90 amp hours nominal. Continual system current is 180Ah, and peak current output is 540 amps for 10 seconds. Using the following equation, each battery module contains 4.8 MJ of energy.

$$E = [V \times I \times 3.6] / 1000 \quad (1)$$

Total energy of the system is 28.77 MJ. The SAE ZE 2017 rules state that a fire and electrical barrier must separate 6 MJ segments of energy for lithium-ion batteries. The aluminum housing of the battery modules along with their internal insulation provide this separation, and two high voltage maintenance plugs in combination with 3 Anderson connectors (separating the six modules into 6 individual cells) serve as the electrical disconnect.

Brammo has been working with SDSMT on battery research and testing, and donated the modules to the team for use in the competition. Each module weighs 22.7 pounds (10.3 kg), for total battery weight of 136 pounds (61.8kg). For comparison, the 8KWh LiFePO4 batteries used on a previous

SDSMT snowmobile had a total weight of 192.5 pounds (88 kg). The almost sixty-pound weight difference is one way the team is reducing weight and meeting some of the team's performance goals.



Figure 13: Brammo 15/90 battery module.

The batteries come integrated with a battery management system (BMS) which consists of protected circuitry within each module and a head unit that communicates between all six battery modules. The BMS protects the batteries from over-charge, over-discharge, over-temperature, balancing, as well as any critical faults. The BMS also controls internal heating of batteries to keep them at optimal operating temperatures in cold conditions. The battery pack is protected by a 250 Amp fuse and all wiring between batteries is 105 °C 2/0 welding cable, which is adequately rated to handle the current carrying requirements of the batteries with the 250A fuse.

Motor Controller

The motor controller used in the SDSMT electric snowmobile is a Sevcon Gen4 Size 6 controller. This controller is rated up to

120VDC and 550 amps, making it a perfect match for the batteries' output. The controller is well protected and has several default settings that make it extremely safe to operate. The controller uses throttle input from the operator to adjust current from the batteries and drive the motor. Additionally, the controller is protected by a 250 Amp fuse on the high voltage input from the batteries. All HV wiring from the batteries to the motor is 105°C AWG 2/0 cable.

The motor controller is normally air cooled, but given its location inside the motor compartment, it does not receive sufficient air flow. The controller must be cooled to reduce capacitance in the chassis caused by the component heating up and producing excessive amounts of 'noise', as found by trial and error of Brammo engineers. This capacitance can alter the function of devices such as the insulation monitoring device. Therefore, the team designed and built a liquid cooled heat exchanger that attaches to the bottom of the controller to counter the heat generated by the controller. This component was previously discussed in the mechanical overview.

Motor

The motor used is a Parker/Brammo GVM1425 IPMAC motor. At peak output, the motor produces 56 HP (42 KW) and 66 lb*ft of torque (90NM). Peak torque is maintained until 4100 RPM, as seen in Figure 15 below. The motor utilizes liquid cooling to maintain consistent performance metrics and to operate more efficiently. Total weight of the motor is 35 pounds (16kg) down 15 pounds from the Curtis AC-20 used on previous versions of the SDSMT snowmobile, which is another significant

weight savings. [4]

The liquid cooling system for the motor is shared with the motor controller. This system uses a small 12v water pump and the stock Polaris heat exchanger located on the front of the tunnel. Coolant is a 50/50 mix of distilled water and ethylene-glycol (automotive coolant). Wiring from the motor to controller is 105°C AWG size 2/0.



Figure 14: Liquid cooled Parker/Brammo permanent magnet AC motor.

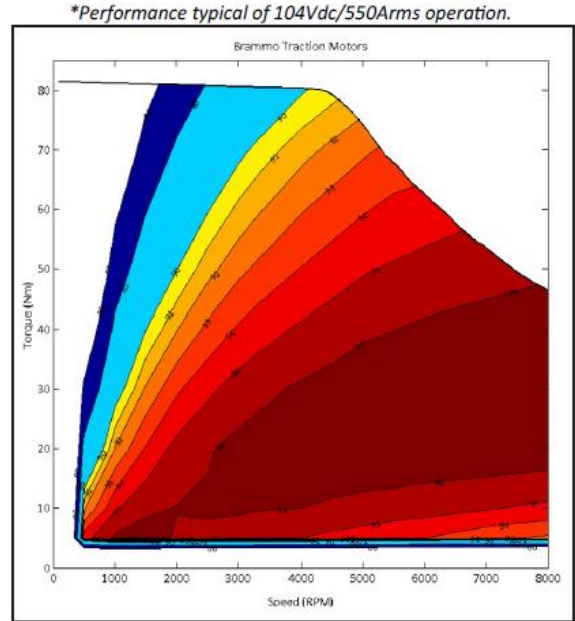

Figure 15: Torque curve of the Parker/Brammo Motor. Peak torque is represented by solid the line at top of curve.

Charger

The primary battery pack is charged using an Eltek-Valere 3KW charger. The charger is located off board and connects to a standard 110/120V wall outlet. Future plans are to make the charger compatible with 220/240V outlets as well as the SAE J1772 charge adapter.

On a 120v outlet, the batteries will charge at a rate 1.1KWh. Charge time is expected to be just under eight hours. The charger communicates with the battery pack and the motor controller via a CAN communications network. This optimizes charging and protects the batteries while charging.

Low Voltage System

The low voltage system is powered by a 12v 3Ah battery, and is activated by the user controlled key switch on the dashboard.

Upon startup of the high voltage, a Sevcon DC-DC converter is powered to act as a stator for the small 12V battery. This prevents discharging of the 12V system before the high voltage system. This also allows the team to only have to charge the high voltage battery pack as the 12V battery is charged from this system. When the 12V battery is activated, a series of relays power on both the BMS and IMD, and powers-on devices such as the headlights, grip warmers and coolant pump. When the key is cranked, a separate series of relays power on the motor controller as well as the final battery isolation relay enabling the high voltage system. This is when the DC-DC converter is powered on to charge the smaller battery and run the low voltage system. At this point, the snowmobile is ready to drive. A fault from the BMS, IMD, or the user pressing the kill switch or pulling the tether will disable all drive system components.

Performance

Range

One of the most important aspects of an electric vehicle is range. Range is a concern with any electric vehicle because it cannot be quickly refueled like an internal combustion vehicle, leading to range anxiety. There is no set formula for theoretically determining range, as range is dependent on a large array of variables such as power, weight, energy available, and overall efficiency of the system, but an estimate can be made using research data and performance characteristics about the drive system.

Using testing data from a previous SDSM&T electric snowmobile, an estimate

of range can be made using estimates of efficiency increases between the two vehicles. With a 4.6KWh battery pack, the older snowmobile will average about 12.6 miles using 80% of the battery capacity. Also given what is known about the weight reduction between the two snowmobiles and the improvement in drivetrain components, a 15% increase per Watt-hour is expected.

$$4.6kWh * 80% * 1000 \frac{W}{kW} = 3680Wh \quad (2)$$

$$\frac{3680Wh}{12.6miles} = \frac{292Wh}{mile}$$

$$292 \frac{Wh}{mile} * 85% = 248 \frac{Wh}{mile}$$

$$8000Wh * 80% = 6400Wh$$

$$\frac{6400Wh}{248Wh/mile} = 25.8 miles$$

Weight difference between the previous chassis and 2017 concepts is about 100 lb. The 2017 snowmobile has a more powerful drive system that is also substantially more efficient. Given this knowledge and the estimate from equation 2, a range of about 26 miles per charge is estimated.

Compared to a gasoline snowmobile that will travel 80 to 100 miles on an eleven-gallon tank of fuel, the range does not appear to be very far, however, the electric snowmobile produces its range at a greater level of efficiency.

A 2004 Polaris RMK 700 with a 144x15x2 inch track belonging to a team member is

comparable to the 2016 SDSMT electric snowmobile in handling and performance. This snowmobile averages about 100 miles per eleven-gallon tank of fuel, or averaging about 9 miles per gallon. (Newer model snowmobiles will average 16 to 20 mpg).

Knowing that one gallon of gasoline contains 115,000 BTU of energy [3], a relation can be formed to find miles per gallon equivalent (MPGe) by finding a ratio of BTU to Watt*hours and considering the energy consumption of the snowmobile in Wh per mile. The relation for the electric snowmobile looks like:

$$MPGe = E_{fuel} / [BTU/Wh * Wh/mile]$$

$$MPGe = [115,000 BTU / gal] / [3.412 BTU / Wh * 8000 Wh / 26Miles]$$

$$MPGe = 109.5$$

(Conversions from “Fluid Mechanics: Fundamentals and Applications” reference [1])

Based on this calculation the minimum efficiency of the electric snowmobile is more than fifteen times the magnitude of the team member’s gasoline snowmobile, and more than five times the efficiency of even the most efficient gasoline powered snowmobile.

Extensive testing with the old gear ratio on the snowmobile showed that over about 200 miles of testing, the average range per charge was about 20 miles in deep snow conditions with the heaviest rider on the team. With the new gear ratio implemented and with a lighter rider, the team expects the

range to meet the 26 miles estimate from the calculations above.

Drawbar Pull

A significant event in the competition is the draw bar pull. This event reflects the machine’s towing capability, which is important for the utility aspect of the snowmobile. Researchers on the ice caps will likely have to carry large amounts of gear and research equipment with them from site to site, and having a machine that will pull a load is important. The SDSMT electric snowmobile team has taken several steps to optimize the snowmobile towing capability.

The rear suspension and track play a large role in towing with the snowmobile. The Polaris Switchback Assault the team uses has a 144x15x1.325-inch track that is pre-studded from the factory. The length and width of the track provide a large surface area to distribute weight and to obtain traction on the snow. The 1.325 inch lugs with studs are able to dig into both soft and hard snow, giving the snowmobile more traction to pull the load forward. The rear suspension features Walker-Evans adjustable shocks which can be adjusted to handle a large array of different weight loads, beneficial for towing.

(3)

On the drive side, the snowmobile uses a single speed fixed gear to drive the track. The chain case gear ratio is 1.81:1 and the ratio of the drive sprocket to driven sprocket for the belt drive is 2.33:1. Final drive ratio between the motor and track drive shaft is 4.22:1. With the torque multiplication of the gear ratio and the torque produced by the motor, peak torque to the track driver is 295

lb*ft, assuming the mass moment of inertia produced by the driven sprocket and chain case have minimal effects on torque transfer. This torque is available from 0 rpm to 4100 rpm and helps give the snowmobile leverage to drive a load forward.



Figure 16: Belt drive from the motor to the jackshaft. Gear ratio is 3:1 (jackshaft : motor)

Capability and Reliability

The SDSMT electric snowmobile team tries to meet the performance metrics presented by the Clean Snowmobile Challenge, but also wishes to make a snowmobile with a wide range of versatility. The goal is to make a snowmobile that performs on the same level as its internal combustion equivalent.

Assuming a consumer market for electrically driven snowmobiles will appear in the near future, SDSMT wants to have a machine that can lead the transition into that market. To do this, the machine needs to match its gasoline competitors in weight, handling, acceleration, and range.

The 2014 Switchback Assault with a full tank of fuel and oil weighs 598 lb according to Polaris test engineers. The 2014 SDSMT electric Switchback weighs approximately

620 lb, or the difference of a couple gallons of extra fuel or gear. The weight breakdown is seen in Table 1 below. With the weight similarity and the weight distribution for the electrical equipment, the electric snowmobile should handle in a very similar manner to a stock Switchback. Power and torque fall between Polaris' 550 fan cooled and 600 liquid cooled engines, giving performance that is comparable to an entry or mid-level gasoline snowmobile. This gives a consumer the ability to ride the snowmobile on-trail or in the backcountry if they choose to do so. The snowmobile will perform on par with its gasoline equivalent, creating a product that is marketable to snowmobilers of all types.

Component	Weight(lbs)
Dry Chassis	300
Battery and container	175
Motor and Controller	65
12V system	25
HV cable and conduit	30
Drive sprockets/misc.	25
Total	620

Table1: Breakdown of weight by components/systems.

The snowmobile should also be more reliable than the gasoline equivalent. With substantially fewer moving parts, and the generally relaxed nature of the electric motor versus a high-strung two-stroke engine, the drivetrain will sustain minimal wear over a longer period of time. The only anticipated annual maintenance will be to

change the chain case oil and check coolant levels. The batteries are durable, and have a long cycle life; greater than 1500 cycles. Maintenance and component wear will be minimal compared to a two-stroke machine.

As far as general safety goes, the snowmobile is very safe. Aside from the user shutdown switches, it has several safety systems that ensure the system is protected, or does not operate if there is a problem. The snowmobile also has protective barriers, such as fireproofing and general component housings that protect a rider from a fault or from accidental contact with an energized component.

Ergonomics

Rider comfort was taken into consideration when building the snowmobile. Features such as a tall windshield and grip heaters were carried over from the stock snowmobile to keep the rider warm and comfortable during a day of riding in cold weather.

The seat of the snowmobile was intended to keep the rider comfortable as well. The seat sits on top of the battery container as seen in Figure 15 below. Utilizing the same thick foam from the stock machine, the seat gives adequate cushion for the rider. The seat is long enough that a rider can move forward or back as they wish to find a comfortable spot. Arms and hands are at a comfortable level for riding even with the taller ProTaper bars on the Switchback Assault. The taller handle bars also allow for a comfortable standing position if the rider chooses to stand.



Figure 17: The seat is comfortable and provides an ergonomically correct riding position. ProTaper handlebars offer both stand up and sit down comfort.

Costs

The 2014 Polaris Switchback Assault retails for \$11,499.00 new [2]. Factoring about 60% of that cost for a chassis without a powertrain, the chassis is valued at about \$7000.00. The chassis alterations, such as changing the cast aluminum chassis support with a steel support affect that value marginally. The cost addition comes from the electrical drive components, with batteries being the primary cost.

Totaling the value of all drive system components, the manufacturer suggested retail price including design and labor, comes to a little over \$30,000.00. This is quite expensive compared to the gasoline powered machine. As current trends dictate, electrical drive systems tend to cost about double what the gasoline equivalent costs. A good example of this can be seen in the Ford Focus Electric. The Focus Electric has a starting MSRP of \$35,170.00, the gasoline Focus starts at \$16,810.00 [5]. As technology improves and the electric drive technology becomes more commonplace in the automotive and power sports industry,

the cost will most likely lower.

The goal of the SDSMT electric snowmobile team is not to produce the least expensive snowmobile possible, but to produce a snowmobile that is as close as possible in terms of performance to the gasoline equivalent. A quality machine that can compete directly with a gasoline snowmobile will help transition the snowmobile market into cleaner machines and open the door to an electric market for both research and recreation applications.

Summary

In closing, the SDSMT Alternative Fuel Vehicle – Electric Snowmobile Team is working to develop a versatile electric snowmobile. Designing and building an electrical system for an application such as a snowmobile present a notable challenge. Placing emphasis on performance, range, and ergonomics, the SDSMT electric snowmobile team is producing a very competitive machine. The snowmobile is relatively expensive, but the quality and technological capability can help to lead the way to a practical and affordable consumer application of the electric drive concept.

References

1. Cengel, Yunus A., and John M. Cimbala. *Fluid Mechanics: Fundamentals and Applications*. 3rd ed. New York, NY: McGraw Hill. 2014. Print.
2. “Polaris Switchback Assault144”. *Polaris.com*. 2014. Web. Feb. 2014. <<http://www.polaris.com/en-us/snowmobiles/600-switchback-assault-144>>.
3. Serebinski, Paul. “Decoding Electric Car MPG”. *Edmunds.com*. 6 Sept. 2013. Web. Feb 2014. <<http://www.edmunds.com/fuel-economy/decoding-electric-car-mpg.html>>
4. “2014 Empulse and Empulse R Specifications”. *Brammo.com*. 2014. Web. Feb.2014. <http://www.brammo.com/empulse_specifications/>
5. “2014 Focus”. *Ford.com*. 2014. Web. Feb. 2014. <<http://bp3.ford.com/2014-Ford-Focus?branding=1&lang=en#/Technology/>>

Acronyms

AC – Alternating Current
AFV – Alternative Fuel Vehicle
Ah – Amp hour
AWG – American wire gauge
BMS – Battery monitoring system
BTU – British thermal unit
CAN – Controller area network
CC- cubic centimeter
DC – Direct Current
g – gravity (acceleration)
KSI – Kip per square inch
KWh – Kilowatt hour
lb – pound force
LiFePO₄ – Lithium Iron Phosphate
MPGe – Miles per gallon equivalent
PMAC – Permanent magnet alternating

Contact Information

Trevor Gunderson
651.252.8573
Trevor.Gunderson@mines.sdsmt.edu
501 E. Saint Joseph St.
Rapid City, SD 57701

current

PSI – Pounds per square inch
RPM – rotations per minute
SAE – Society of Automotive Engineers
SDSMT – South Dakota School of Mines
and Technology
TIG – Tungsten inert gas
V - volt