

Team QuiETS

The Machine

2009 600cc MXZ E-TEC TNT



Past Accomplishments

- HPDI tuning
- Improved exhaust design
- Identified potential trouble spots

Current Objectives

- HPDI optimized tuning
- Optimized and reduced oil injection
- New compact exhaust
- Catalyst integration

Tuning Optimisation

- Fine-grain adjustments
- Additional parameters considered by ECU

$$inj_{final} = inj_{base_{RAVE}} + FlexFuel + ATS + CTS + EGT + Post_start$$

Flex-Fuel



Flex fuel sensor

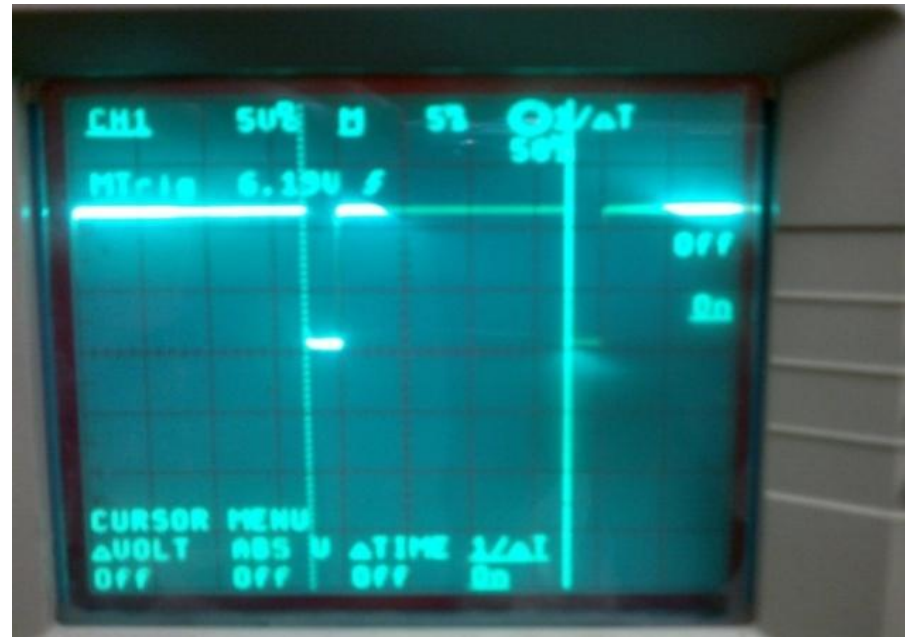

Output: 50Hz-150Hz

Fuel Temperature monitoring

- Flex-fuel sensor also outputs temperature
- Not currently used by ECU

Oil Mapping

- The oil injection map is now based on the desired fuel:oil ratio

	0.00	10.00	20.00	30.00	40.00	50.00	60.00	70.00	80.00	90.00	100.00
0.00	200.00	200.0	200.0	200.0	200.0	200.0	200.0	200.0	200.0	200.0	200.00
500.00	200.00	200.0	200.0	200.0	200.0	200.0	200.0	200.0	200.0	200.0	200.00
1000.00	200.00	200.0	200.0	200.0	200.0	200.0	200.0	200.0	200.0	200.0	200.00
1500.00	85.00	85.00	85.00	85.00	85.00	85.00	85.00	85.00	85.00	85.00	85.00
2000.00	81.67	81.67	81.67	81.67	81.67	81.67	81.67	81.67	81.67	81.67	81.67
2500.00	78.33	78.33	78.33	78.33	78.33	78.33	78.33	78.33	78.33	78.33	78.33
3000.00	75.00	75.00	75.00	75.00	75.00	75.00	75.00	75.00	75.00	75.00	75.00
3500.00	71.67	71.67	71.67	71.67	71.67	71.67	71.67	71.67	71.67	71.67	71.67
4000.00	68.33	68.33	68.33	68.33	68.33	68.33	68.33	68.33	68.33	68.33	68.33
4500.00	65.00	65.00	65.00	65.00	65.00	65.00	65.00	65.00	65.00	65.00	65.00
5000.00	61.67	61.67	61.67	61.67	61.67	61.67	61.67	61.67	61.67	61.67	61.67
5500.00	58.33	58.33	58.33	58.33	58.33	58.33	58.33	58.33	58.33	58.33	58.33
6000.00	55.00	55.00	55.00	55.00	55.00	55.00	55.00	55.00	55.00	55.00	55.00
6500.00	51.67	51.67	51.67	51.67	51.67	51.67	51.67	51.67	51.67	51.67	51.67
7000.00	48.33	48.33	48.33	48.33	48.33	48.33	48.33	48.33	48.33	48.33	48.33
7500.00	45.00	45.00	45.00	45.00	45.00	45.00	45.00	45.00	45.00	45.00	45.00
8000.00	41.67	41.67	41.67	41.67	41.67	41.67	41.67	41.67	41.67	41.67	41.67
8500.00	38.33	38.33	38.33	38.33	38.33	38.33	38.33	38.33	38.33	38.33	38.33
9000.00	35.00	35.00	35.00	35.00	35.00	35.00	35.00	35.00	35.00	35.00	35.00

Sample values

Acoustic Improvements

- Panel damping
- New compact exhaust design

Cab Insulation



2012 Panel damping

2012 Exhaust Design

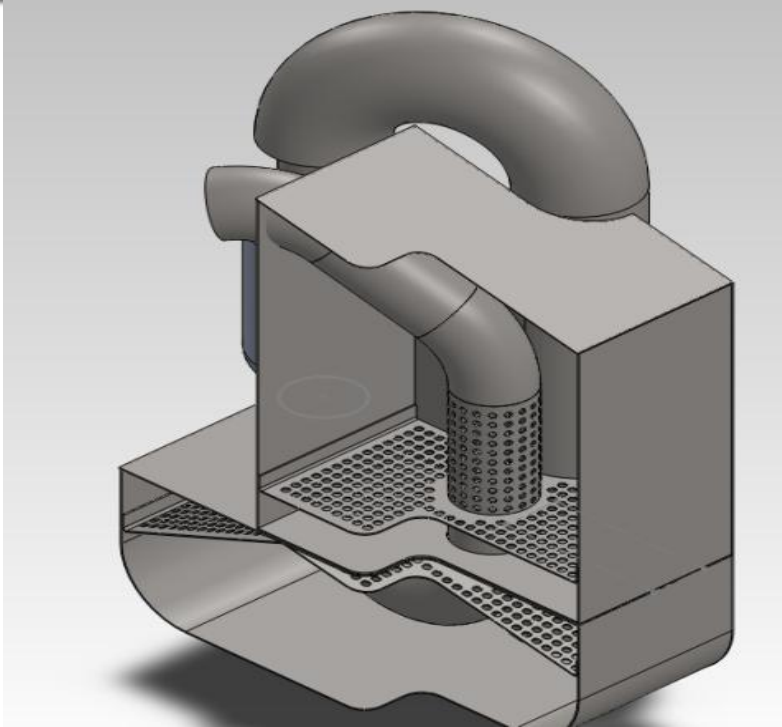

2012 exhaust CAD model

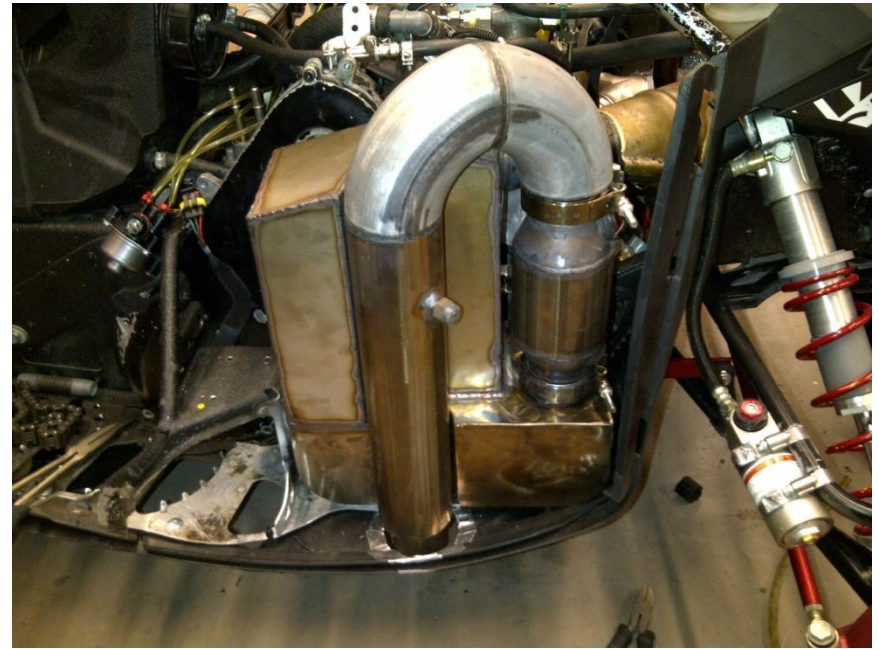

Final 2012 exhaust product

Sound level testing

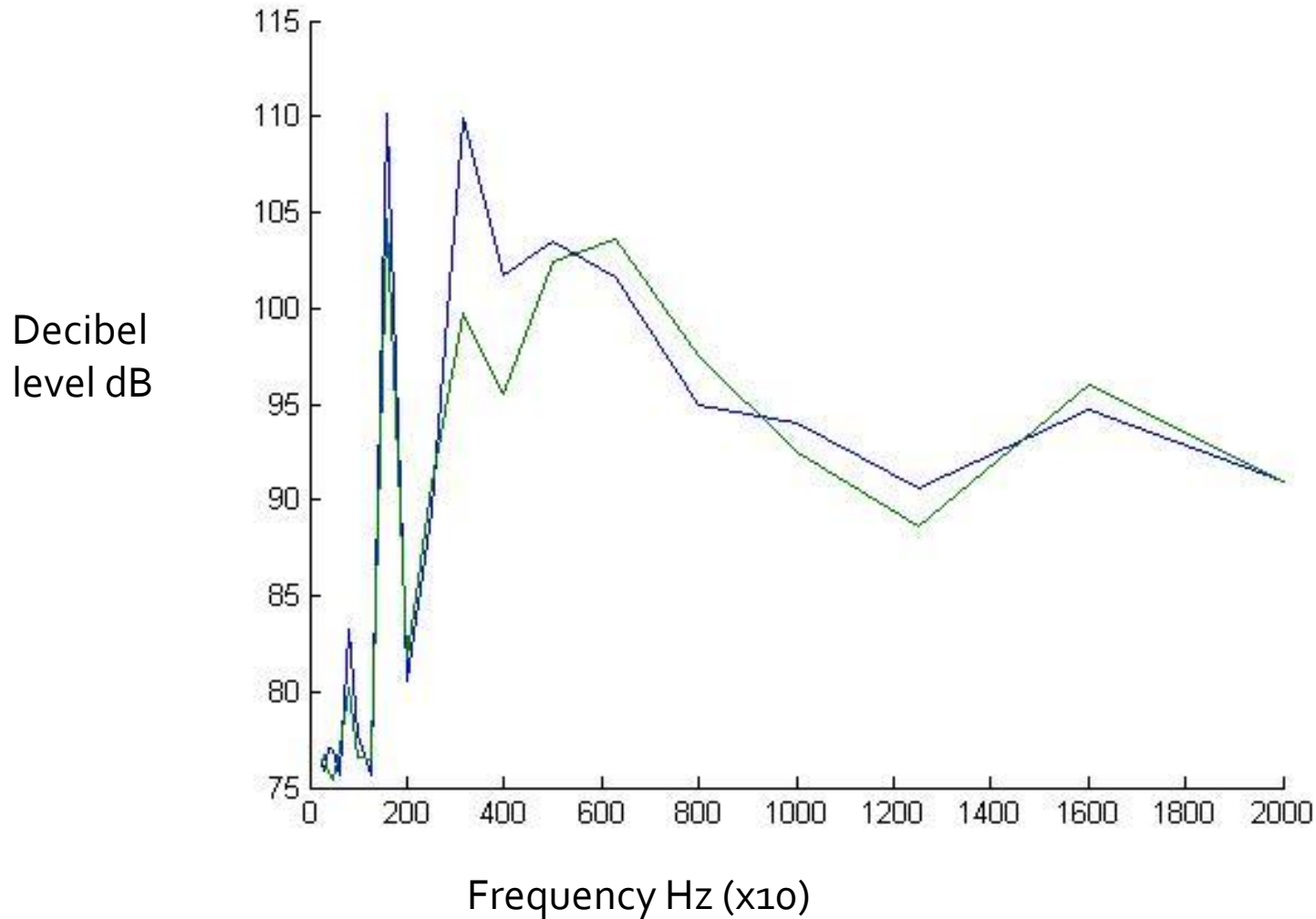

Catalyst integration

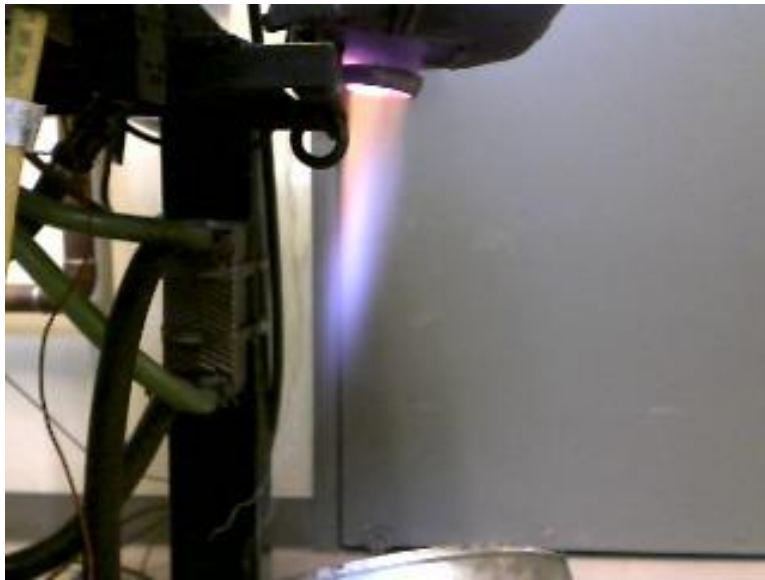

2011 Oxidation catalyst



2012 Three way catalyst

2012 CO% levels

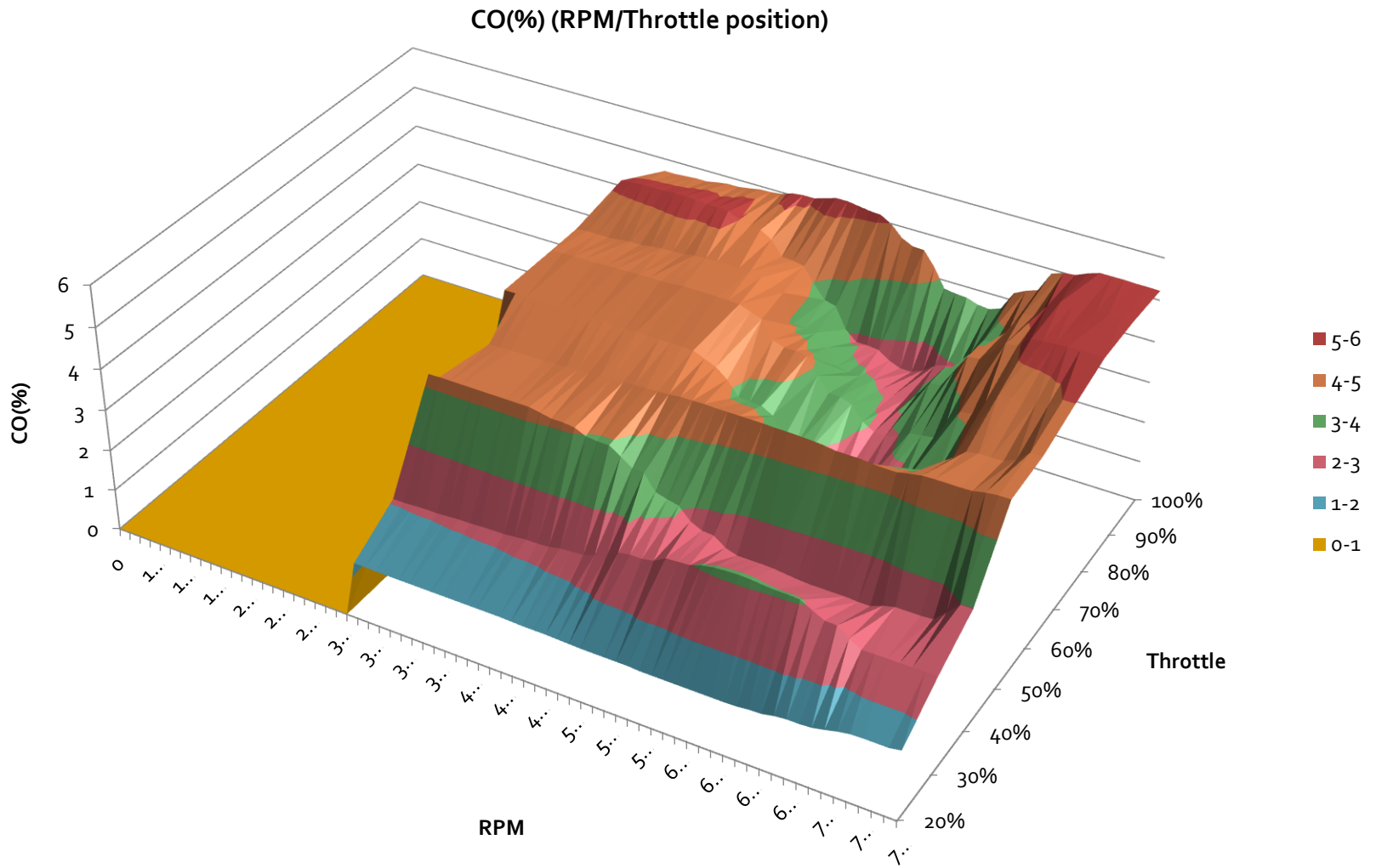

Previous CO % levels

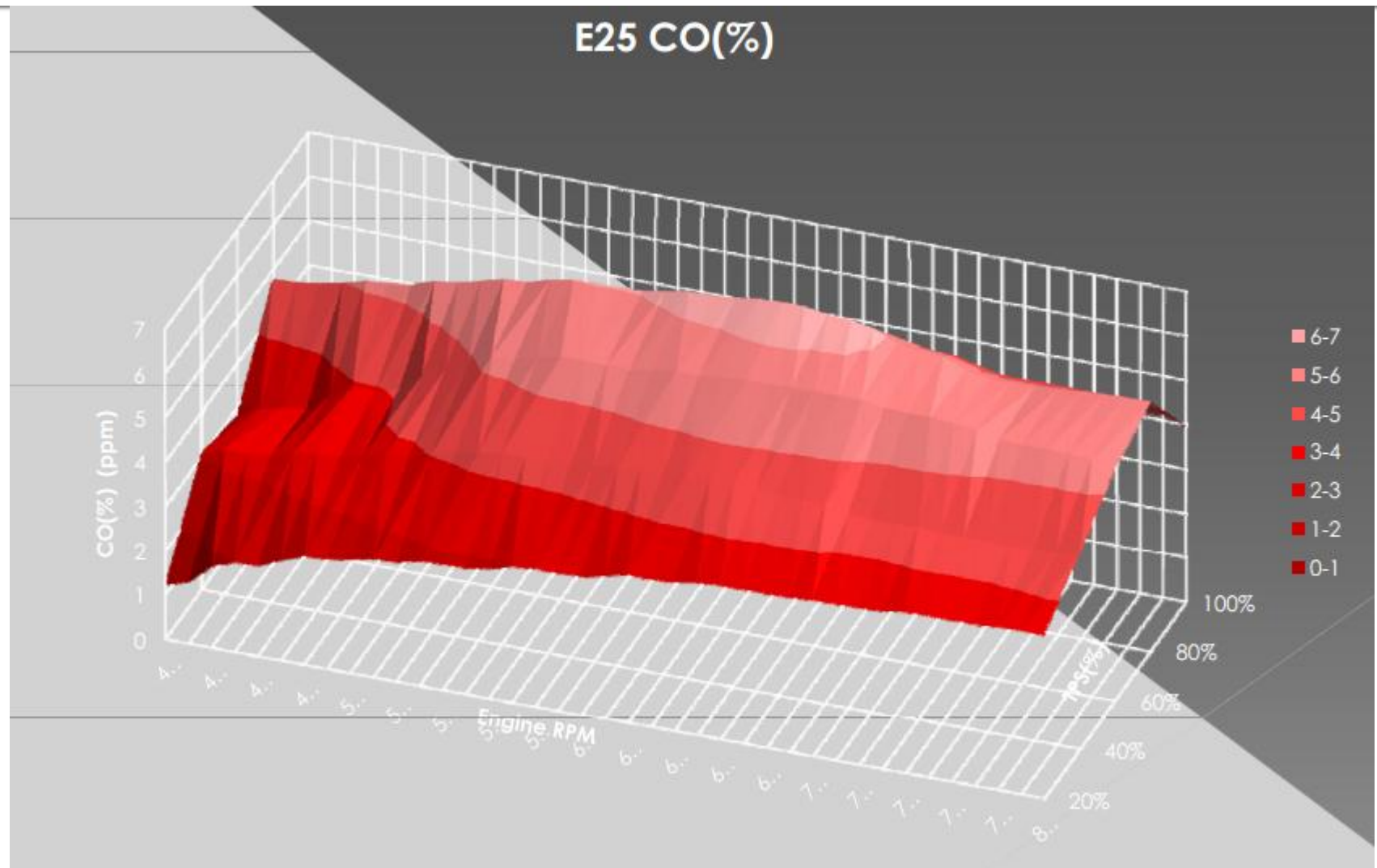

2012 NOx levels

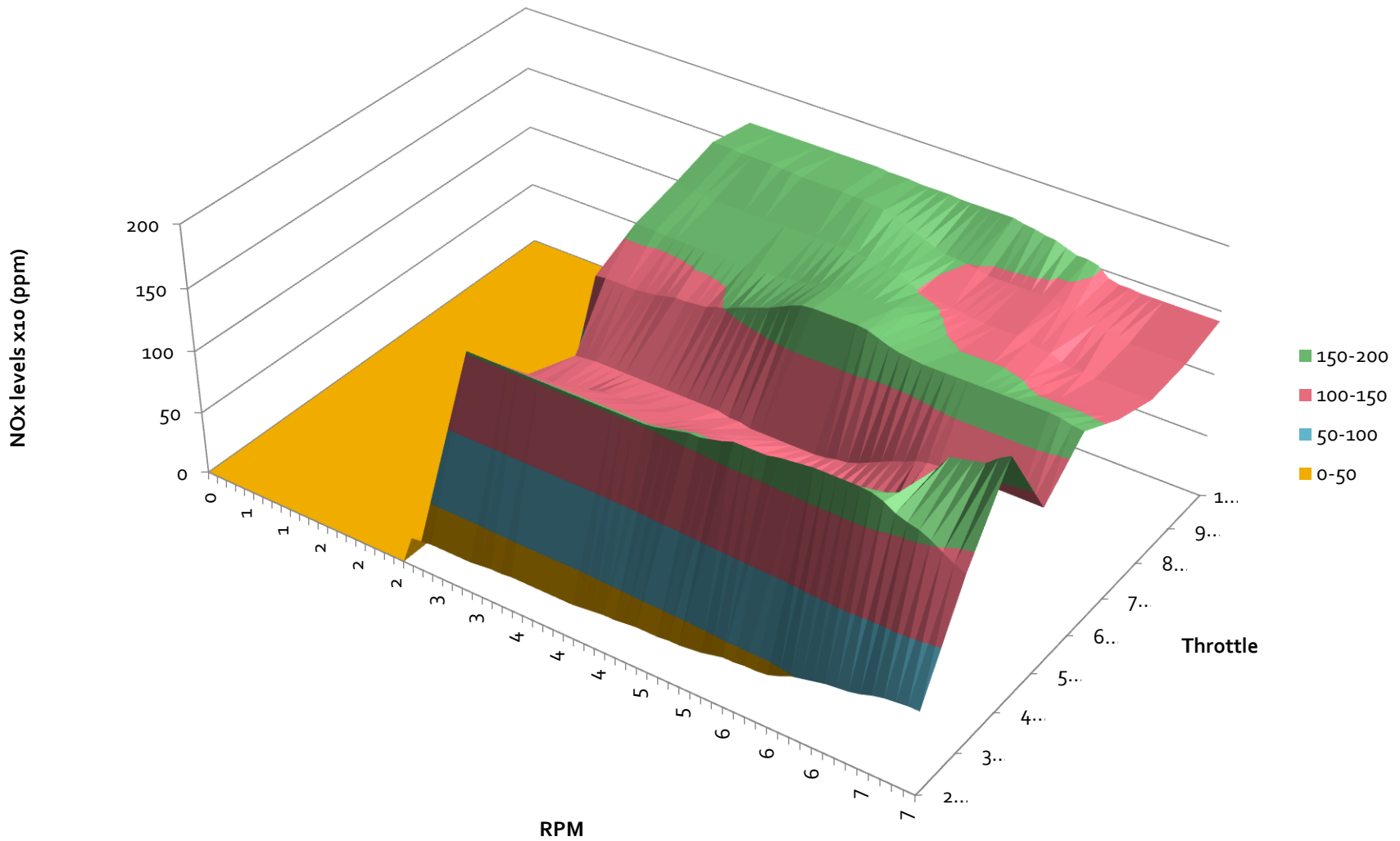

Previous NOx levels

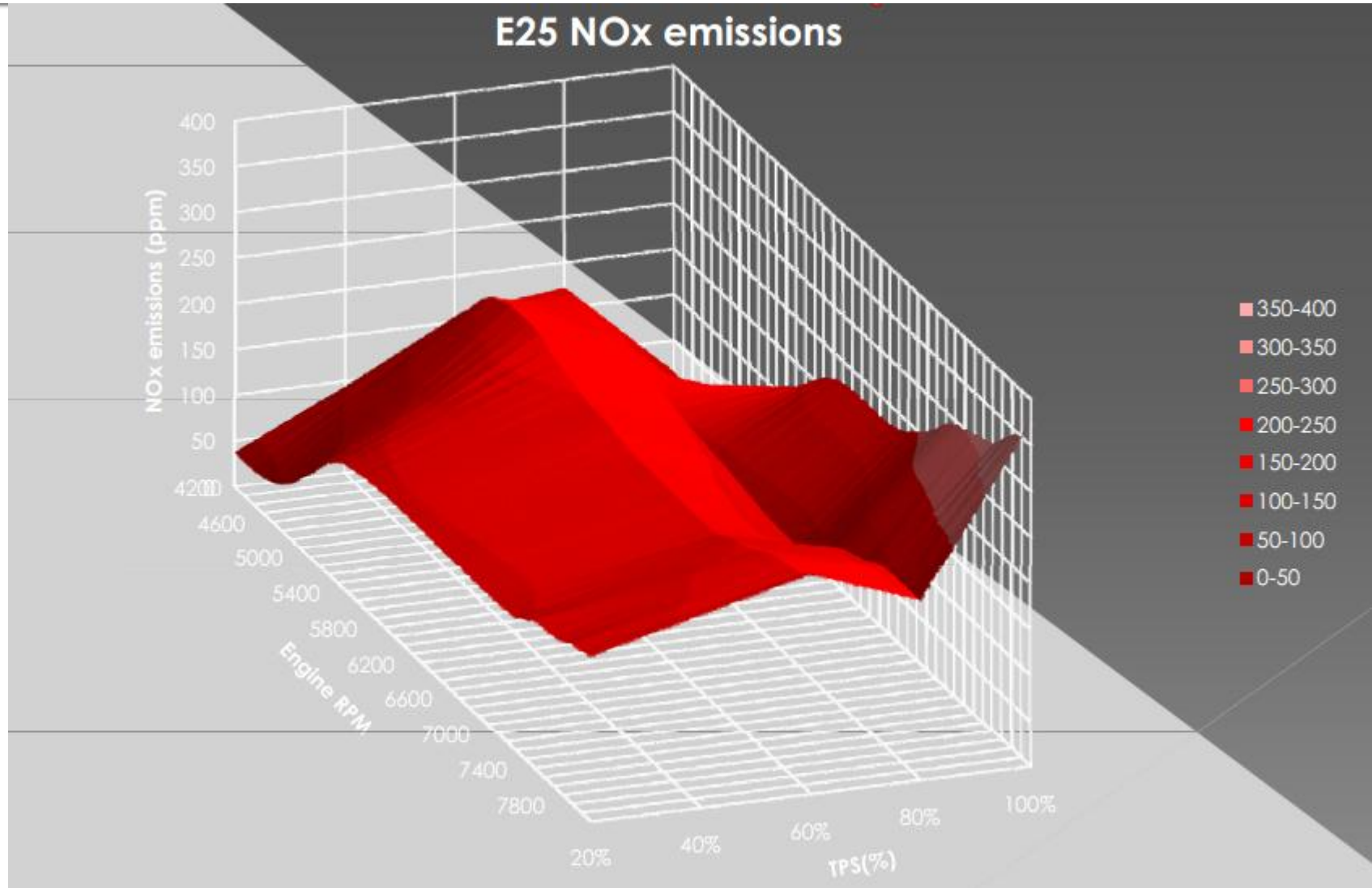

2012 HC levels

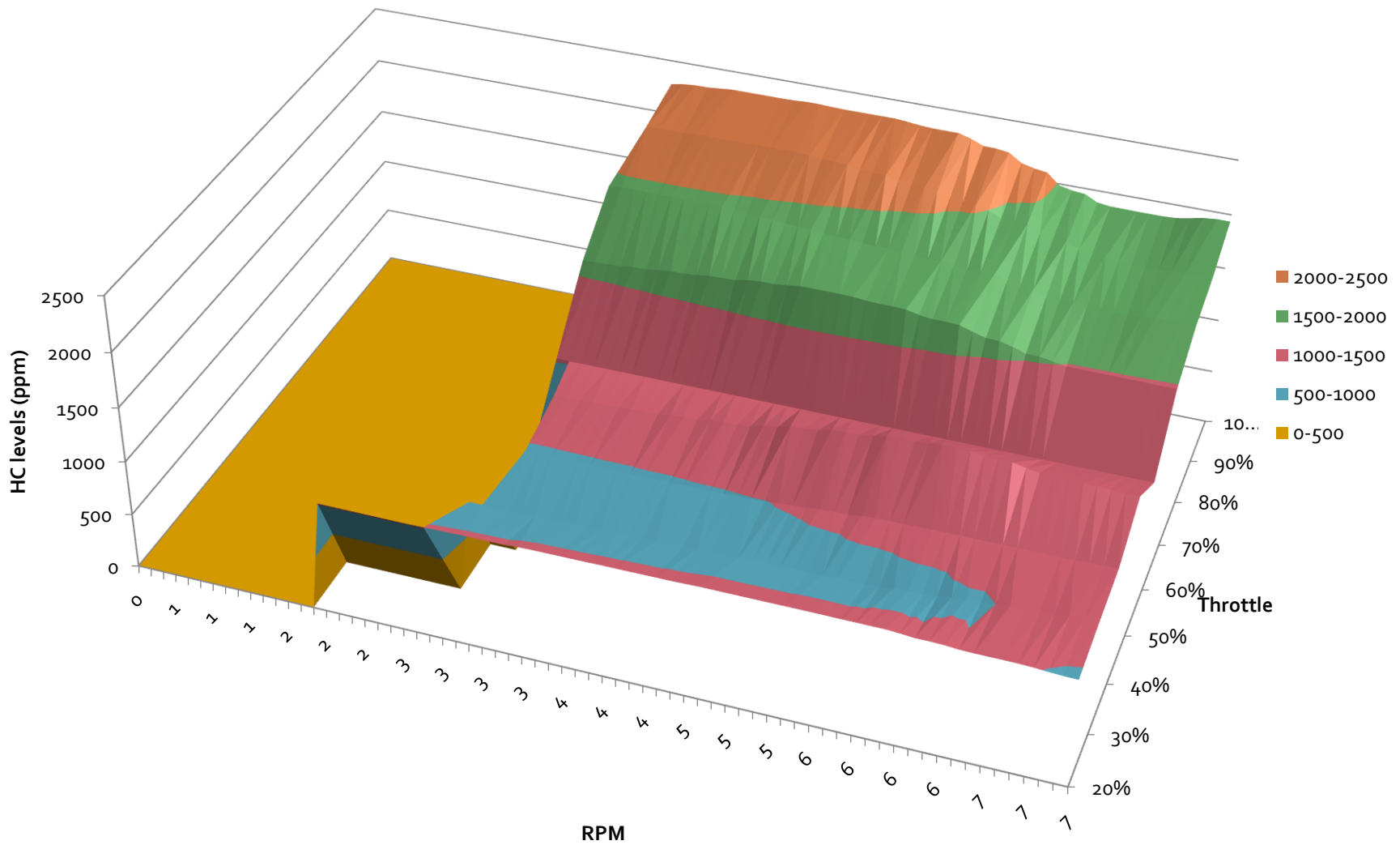

Previous HC Levels 2011

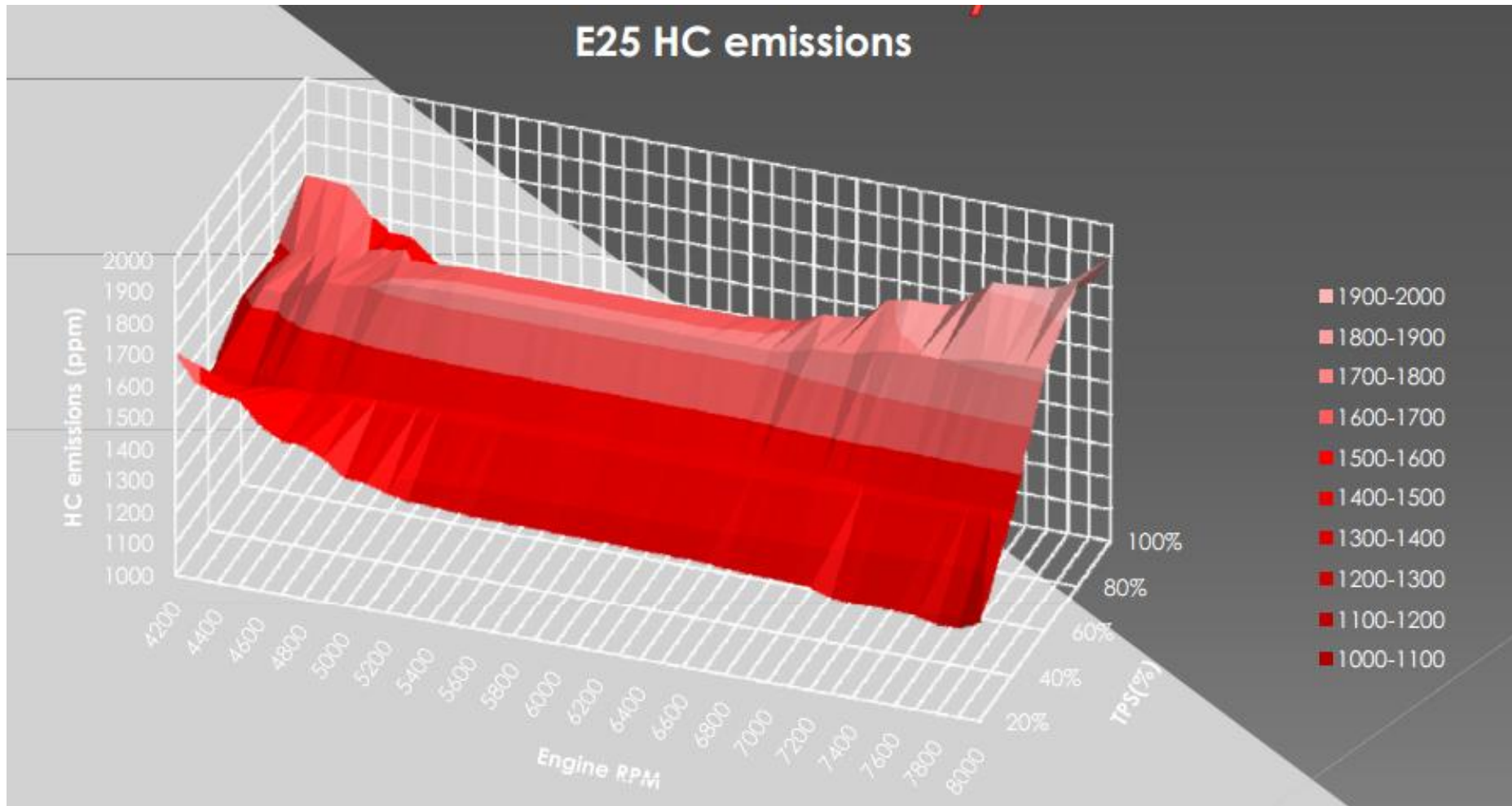

Conclusion



THANK YOU