

2011 Clarkson University Electric Snowmobile

Leif Amber, Michael Arlan, Michael Bogardus, Newton Hausermann, Erin Kinney,
Peter Kudrewicz, Brian Loggi, Edward Petrak, Jeannie Piekarz
Clarkson Electric Knights

Copyright © 2011 SAE International

ABSTRACT

The objective of this competition is to create a zero emissions snowmobile that can be used at Summit Station, Greenland. The sensitive nature of the research that is being conducted at this specific site calls for the use of alternative energy methods. Starting in 2007 Clarkson University built an Electric Snowmobile to participate in the SAE Zero Emissions Snowmobile Competition. For the current design, the team modified a 2008 Polaris 600RR and converted it into a fully electric snowmobile. The 2009-2010 team then further developed the sled. The Lithium Polymer (LiPo) battery chemistry proved unsafe and unreliable, requiring a transition to Lithium Iron Phosphate (LFP) chemistry. The chemistry of the LFP batteries had superior thermal capabilities and chemical stability when it was compared to the LiPo chemistry. The battery system consists of 816 individual cells that provide 6.8 kWh of energy and up to 57 kW of power. An Elithion Battery Management System (BMS) monitors and equalizes the batteries for safety and performance. An Azure Dynamics motor controller powers a brushless 3-phase AC induction motor. The motor is moved from its original mount location for simplification of the drive system and to improve handling. A 2 pulley system with a 4:1 ratio optimizes torque for maximum power delivery to the track. The stock track has been replaced to increase traction and a composite skid frame has been implemented to reduce weight. These modifications were made without compromising rider comfort when compared to a stock 600 RR. At competition this past year, the snowmobile pulled 737lbs in the draw bar pull event, achieved a range of 10.5 miles in close to worst possible conditions with no load.

INTRODUCTION

With important ongoing research regarding the global cycling of atmospheric chemicals at Summit Station on the Greenland Ice Cap, the National Science Foundation (NSF) is working with the Society of Automotive Engineers (SAE), looking for a vehicle to provide transportation between research sites. The research at Summit station measures some of the chemical factors in parts per billion. With this data being so sensitive to its environmental surroundings, emissions from an internal combustion (IC) vehicle would distort research data. As a result, there is a need for a zero-emissions vehicle. To be able to support researchers and equipment, this vehicle has to be able to carry a significant load over a reasonable distance. Traditionally, electric vehicles were limited by range, but continued advancement in technology is providing increased viability of such vehicles. With a zero-emissions form of transportation, researchers will be able to access areas they would previously only approach by foot, so as not to affect data. It will also allow more distant satellite camps, thus cutting down even more on the carbon footprints left by the researchers. The SAE Clean Snowmobile Challenge strives to address this issue in an attempt to provide an alternative mode of transportation.

Since 2008, the Clarkson University Snowmobile team has worked to convert a Polaris 600RR Snowmobile from internal combustion to fully electric. For the 2008 competition the main goal was converting the previous internal combustion vehicle to a fully electric snowmobile. In 2009, extensive work was done to reduce weight, as well as increase the power output to the motor. For the 2010 challenge, the charger was improved and a new battery pack was installed, along with a new motor mount, new belt case, and new battery balancing system. This year for the 2011 SAE Zero Emissions Snowmobile Challenge, further revisions have been made to improve reliability and performance of the snowmobile, including a new skid frame to reduce weight, better rider protection system, and further improvements to the charger.

DESIGN STRATEGY

Based on the 2010 Clean Snowmobile Challenge results, and experience with the snowmobile's use at the Greenland Summit station over the summer, the team determined several necessary improvements for the snowmobile to improve performance, safety, and the reliability of the snowmobile. Additionally, Table 1 shows the events that will earn points for our design at competition. The main improvements between 2010 and 2011 are to: improve reliability and safety of the snowmobile, and reduce weight to improve the range of the snowmobile. In order to accomplish this, the team has: replaced the skid frame with a lighter model and built a safer charger in a new case.

One continuing goal is to keep the design similar to a stock IC snowmobile, in both aesthetics and maneuverability. Any modifications are encompassed within the space envelope of the stock snowmobile. An even weight distribution is also necessary to provide similar handling. This helps to ensure a similar rider comfort and aesthetics to the original stock Polaris 600RR, which makes the electric snowmobile more appealing to the current consumer market.

The first goal this year was to take sufficient data to support previous range estimates for the snowmobile. All scientists need data to prove the performance of an experiment, and the snowmobile must be tested sufficiently to answer consumer questions about the range, top speed, and towing capacity. Therefore, the snowmobile's testing in Greenland has helped support some of the conclusions made in this paper. The second goal was to reduce weight. In order to do so, the skid frame was replaced with a lightweight composite model. The charger was the third goal, in need of a new case and some components to improve its safety and performance.

Previous Work

During the past several years, the team has worked to convert an IC snowmobile to a fully electric utility snowmobile. This past year safer, more reliable batteries were chosen to power the snowmobile, an improvement over the lithium polymer cells used in previous versions of the snowmobile. These batteries needed to meet specifications for output current, voltage, and operate in conditions required by competition and the NSF. A high power density is desirable to supply as much power as possible at a relatively low weight. With a high power density it is possible to get the power needed to complete the events that require the snowmobile to run under a load. With more power the events such as the Draw Bar Pull, as well as the new event, Range + Load + Handling, are accomplished more easily. must also have a volume that can be enclosed within the available space in the snowmobile, so as to maintain the aesthetics. Finally, a reasonable cost is preferable, and since cost is one of our main goals, there was a very large portion of time spent researching the least expensive parts that would not sacrifice the safety or overall performance of the snowmobile.

As the main power system involves a large quantity of cells, it is necessary to use a Battery Management System (BMS) to regulate the system. This BMS equalizes each individual pack as well as preventing any pack from sinking below the minimum operating voltage. By protecting the batteries from falling lower than its minimum voltage, no one battery will cause the entire battery system to perform poorly or fail. Included within the BMS is the capability to sense variables of each battery pack to allow the user to monitor the system. A close watch of the temperature, voltage and current output of the batteries can be used to keep the snowmobile operating safely. For example high temperatures, currents or drops in voltage are all indications that the snowmobile needs to be serviced.

Balancing the speed and torque applied to the track is also necessary to increase the snowmobile's performance when towing a load. The use of a more efficient motor controller allows more power to pass from the main battery system to the motor increasing both speed and torque. Secondly, the gear ratio can be adjusted. Speed and torque are inversely related with this adjustment; in other words an increase in speed leads to a reduction in torque and vice versa. With less emphasis on acceleration and the added event requiring the snowmobile to tow 1000 pounds for at least one mile, more torque is needed. While taking into account that the events are still time based, ratios for gears still need to be able to provide the torque needed, while moving at a utilitarian speed.

Another improvement made to the conversion was the elimination of the oil-filled chain drive system. Instead a belt driven drive system was implemented. Use of a belt driven system, instead of the chain drive makes the snowmobile substantially quieter. Not only does switching to this system help with the noise event, but in fact it played an important part in helping with the handling of the snowmobile. In the process of switching to a belt driven system, the placement of the motor was altered. The motor was moved to a position lower than it was in previous years allowing a more desirable center of gravity for the snowmobile, improving handling.

Through past years at the Clean Snowmobile Challenge the weight of the snowmobile has varied due to changes in the design. To help improve performance, the team sought to reduce weight where possible on new and existing components on the snowmobile. With a lower weight less energy will be needed to the snowmobile, thus giving it a larger range.

NSF and Competition Goals

The goal of the competition in Michigan is to determine whether an electric snowmobile can be adequately used in Greenland's Summit Station by the NSF. The most important events in the Michigan competition are the range, draw bar pull, range + load + handling, subjective handling, and cold start events, as these are critical to the snowmobile's use at the research station in Greenland. While the other events are important to the snowmobile, and can help increase the market for the snowmobile, the snowmobile must perform well in these events to be useful in Greenland. Table 1 lists every event in the competition, and selected events are described in more detail below.

Table 1: Possible points to obtain based upon snowmobile events. [5]

Zero Emissions Class Events	Points for Passing Event	Maximum Additional Points
Manufacturer's Suggested Retail Price (MSRP)	N/A	50
Weight	N/A	100
Range	N/A	100
Draw Bar Pull	N/A	100
Range + Load + Handling Event	N/A	100
Subjective Handling	N/A	50
Cold Start	50	N/A
Static Display	50	N/A
Objective Noise	N/A	75
Subjective Noise	N/A	75

The draw bar pull test is where the snowmobile must pull a progressive resistance at four miles per hour until it can no longer proceed due to loss of traction or power. During the test the driver is not allowed to bounce the sled for traction. The maximum draw bar pull load will be measured and the snowmobile that pulls the maximum load will be declared the winner. Providing an adequate amount of torque and traction are necessary for this event, resulting in the addition of track studs and the design of the drive system.

For the range event, the judges set a specific speed limit that the snowmobile must travel at until it cannot move any farther. New to the range test this year is if a vehicle goes over ten miles then a calculated number of points based off of how efficient the snowmobile is will be added to the 100 points awarded for making the 10 miles. Therefore, high energy batteries have been chosen, and improvements to efficiency and to reduce weight will improve the range of the snowmobile. This year, a new composite rear suspension (skid frame) has been included to help reduce weight and improve range.

Another event is the objective handling and drivability event. This consists of a student from the team driving the sled through a slalom type course as fast as possible without incurring any penalties. Each penalty costs one second. Each team is allowed two attempts and no adjustments are allowed to be made to the sled in between the two attempts. This demonstrates the drivability of the snowmobile, which is important for researchers that may not drive a snowmobile every day. A snowmobile that is easier to maneuver will be safer and perform better, so the team has made efforts to keep the handling as close to the stock snowmobile as possible, in selections of battery placement and weight distribution.

The acceleration testing event is to determine the acceleration performance of each snowmobile. Driven by a student from the team, starting from rest they then will try to accelerate to maximum speed within 500 feet. From start to finish the snowmobile will be timed. Approximately 500 pounds will be added to the Zero Emissions snowmobiles. While acceleration is not a high priority for a snowmobile's use in Greenland, it can help make operations at Summit Station more efficient with respect to time.

BATTERY SELECTION

The main goal of the electrical system is to provide enough energy to power the snowmobile using batteries. This required deliberation over which batteries would provide enough power to the snowmobile while maximizing safety, rider comfort, ease of handling, and operation in a cold environment. Several factors were used in the analysis of possible batteries for the electrical system including: battery chemistry, operating temperature, energy density, price and safety.

BATTERY CHEMISTRY- The first decision on what battery to select is which type of chemistry should be used. Table 2 compares four common families of rechargeable batteries for electric vehicles.

Energy density is the main property for deciding which battery chemistry to use. Energy density is measured as the amount of energy stored in a given unit of mass or volume. A high energy density is preferred as it would weigh less and take up less space. For example

based on the data in Table 2, it takes approximately 6kg of Lead Acid batteries or 2kg of Nickel Metal Hydride batteries to provide the same amount of energy as a 1kg Lithium Ion or Lithium Polymer (LiPo) batteries. Lithium Ion and LiPo batteries have a clear advantage when comparing the different chemistries on energy density. Figure 1 helps visually show the advantage of using these chemistries.

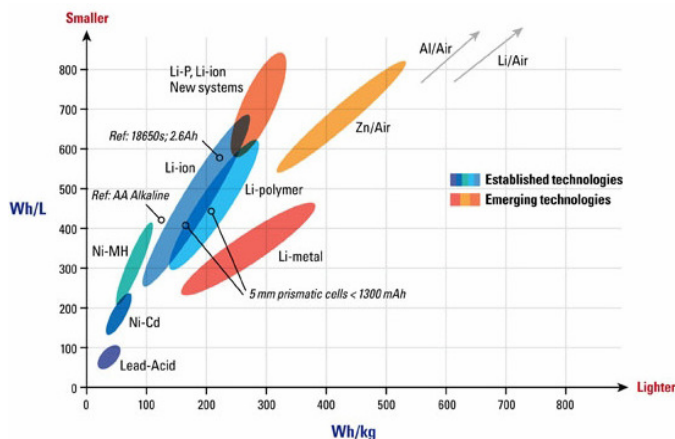

Figure 1- Comparison of volume energy densities and mass energy densities for different battery chemistries. [1]

COMMON BATTERY CHARACTERISTICS- The second consideration for the batteries was the temperature at which they could effectively operate. The batteries would be incorporated in a snowmobile that will be operating at sub-freezing temperatures. Specifications for the battery must show that it will be able to operate at these temperatures. Lithium Polymer cells will see a decrease in performance at low temperatures quicker than the other chemistries. The Lithium Ion Batteries are rated for -20°C , which does not meet the required -40°C for competition. As a result, separate tests were conducted by our team to test the batteries capabilities for the required temperatures; the data is shown in Figures 2 and 3.

Another important characteristic of the batteries is price. The final price of the electric snowmobile must be affordable for those who want to use them. Rechargeable batteries can be used many times before their useful lifespan expires. A battery’s useful life span is a measure of how many times the battery can be charged and discharged before it is no longer able to function correctly. A longer life span can also help make up for the cost of the batteries. Lithium Ion batteries can be between 2 to 5 times more expensive than other chemistries, but can have a life cycle that is at least 2 times as long. Lithium Ion batteries will last longer, offsetting the cost of buying the more expensive chemistry.

Table 2: Characteristics of common rechargeable battery chemistries. Values for energy density and cost are relative to each other ranging from 1X to 10X; 1X being the best and 10X the worst. [2]

Battery Type	Lead Acid	NiMH	Lithium Ion (LiCoO)	Lithium Iron Phosphate	Lithium Polymer
Mass Energy Density (Wh/kg)	6X	2X	1X	1.78X	1X
Volume Energy Density (Wh/L)	5.5X	1.5X	1X	1.5x	1X
Cost (\$US/Wh)	1X	5X	5X	6x	10X
Recharge Cycles	500-800	500-1000	500	2000	500
Operating Temperature ($^{\circ}\text{C}$)	-20 to +50	-10 to +60	-20 to +60	-20-60	-20 to +60

The final requirement for the batteries is safety. Safety is always of the utmost importance. Therefore, batteries that can withstand the vibrations and movements of the snowmobile need to be used. After experience with Lithium Polymer batteries in the 2009 design, it was decided that a change in battery chemistry was needed. These cells are very unreliable and are connected with flimsy tabs, which are difficult to work with. A short circuit of these cells creates hazardous smoke emission, and significant heating, which can cause a fire.

FINAL SELECTION- Taking all of these characteristics in account, batteries with a lower energy density such as lead acid and nickel metal hydride would be cost effective, but a large amount of mass and volume would need to be incorporated into the snowmobile design. This results in adverse effects on major goals such as weight, aesthetics, handling and rider comfort. On the other hand, Lithium Polymer batteries would have the preferred energy density and have a somewhat reasonable cost. Unfortunately using this chemistry in the past has proven them to be unsafe, unreliable and with a short life span due to a relatively low life cycle.

Lithium Ion batteries are the clear choice for this application. They have a much larger energy density which improves the overall performance of the snowmobile. Though they may be more expensive than chemistries with lower energy densities, the increase in performance is essential. Their life cycle can also be significantly longer offsetting the higher price. The final chemistry chosen for was Lithium Iron Phosphate (LFP). This is a chemistry that is becoming increasingly popular in electric vehicle applications.

Table 3: Nominal values of K2 high energy and high power battery cells.

Cell Type	[3] High Energy (LFP26650EV)	[4] High Power (LFP26650P)
Average Voltage (V)	3.2	3.2
Max Current (A)	12	42
Capacity (Ah)	3.2	2.5
Energy Density (Wh/kg)	125	103
Power Density (W/kg)	390	725
Cell Weight (g)	82	82.5
Cost (\$)	5.00	6.75

K2 Energy LFP cells were chosen and came with the option of either high energy or high power cells. Table 3 shows the comparison of the nominal values for these two models. Originally the High Energy model (LFP26650EV) was considered because of cost. These cells also have slightly more energy resulting in a longer range for the snowmobile. However, a battery system of these cells would only supply up to 31kW; less than the motor’s maximum power of 37kW. This would result in the batteries limiting the power of the snowmobile. These cells also have a lower maximum current capability of 10A. Figure 2 shows the average discharge characteristics found by testing both types of cells.

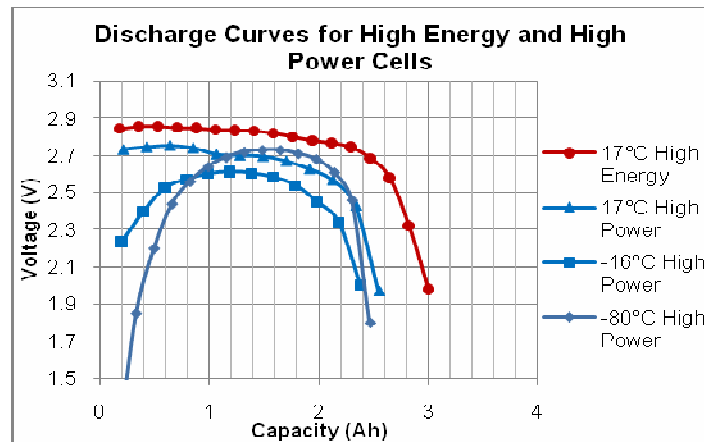

Figure 2 - Discharge curves of both High Energy and High Power K2 Cells. High Power Cells were also discharged under different temperature conditions. Note that the -80°C data is for cells that were soaked in -80°C and then discharged at -1°C due to equipment limitation

The High Power model (LFP26650P) was chosen because of its higher available power output. A system made up of these cells can provide up to 57kW and are capable of supplying 714A. These cells have an 85.9% power gain for a 17.6 % energy loss. Thus these cells shorten the range of the snowmobile but give it the ability to pull a larger load.

The manufacturer rates these cells for temperatures down to -20 °C. This does not meet the specifications of -40 °C needed in the sub arctic regions. In order to confirm that the batteries would work well in the Greenland Ice Cap, the cells were tested at low temperatures to determine how well they would perform. The performance of the cells while discharging was tested in three different conditions. The first two tests involved discharging a battery in ambient temperature of 23.1 °C and -16.8 °C. Due to equipment limitations, testing of a cell under an ambient temperature of -40 °C could not be achieved. The final test was instead done with a

battery that had been under -80 °C conditions for a week; it was then discharged in an ambient temperature of -1 °C. Figure 3 shows the voltage discharge of these batteries over time.

Effective discharge of the cells was seen under each condition. Cells under colder conditions dropped to lower voltages initially and would warm up due to their internal resistance. An effect of the colder temperatures led to a longer warm up time. Discharge of the cell beginning at a temperature near -80 °C shows that these cells will work after being exposed to temperatures even colder than the arctic region. Under an ambient temperature of -40 °C it is expected these cells will perform with a comparable discharge and self heating cycle.

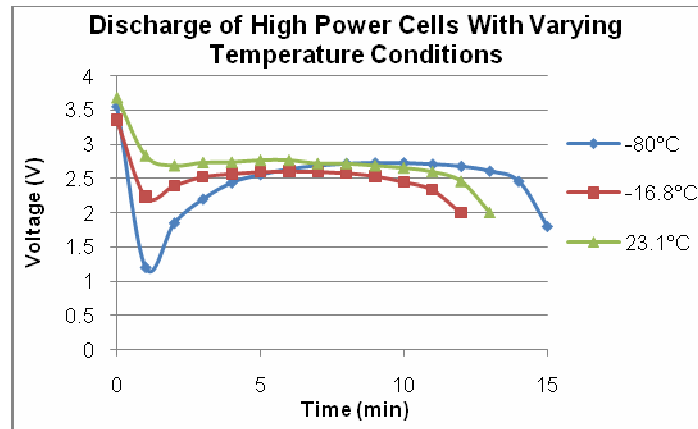

Figure 3 - voltage discharge of batteries in different ambient temperatures. (80°C denotes soak temperature discharge temperature was -1°C

These cells have also been shown to be safe under short circuit conditions. A representative from K2 Energy stated “we have never seen one of our cells fail as a hard short in the field”. It is possible that a cell can “soft short” by slowly self-discharging if it has been damaged by over-discharging below 2.5V [10]. A short circuit test showed safe discharge of an individual cell. Immediately after being shorted the cell output a current of 161.4A and then quickly dropped. At an ambient temperature of -7°C the cell discharged over 60 seconds and heated up quickly reaching a maximum temperature of 97 °C. The batteries have safety features that allow them to vent electrolyte at 175°C to prevent explosion. The 104°C increase in temperature due to short-circuiting a cell would not cause the electrolyte to be vented. However in order to ensure the safe operation of the cells a fuse linking system is implemented to protect against short circuits. Each cell is connected to the cell next to it using a resettable fuse to prevent too much current from coming from a single cell in a parallel pack.

MAIN POWER SYSTEM – A total of 816 LFP26650P cells purchased from K2 Energy provide the power to drive the motor. The Solectria AC21-A motor requires a nominal supply of 144 Volts. To supply this required voltage, 48 packs are wired in series to provide an average nominal voltage of 153.6V. Each battery pack consists of 17 batteries wired in parallel that can provide up to 714A. The entire system is capable of supplying 57kW, greater than the motor’s maximum rated power of 37kW. It can also store up to 6.8kWh of energy. The entire pack of LFP batteries costs \$5,500, a decrease from \$8,800 for the LiPo battery pack from the 2009 design.

One major aspect of implementing these cells is designing battery boxes that can contain them. The cylindrical cells required a different design from the prismatic cells used in 2009. Seven different banks were designed to hold the 48 packs (see BMS section for more details). Six of them contain seven packs and the last has six. Between every pack is a piece of brass connected to a spring providing a flexible and conductive surface to connect the packs in series. To ensure contact isn’t broken due to motion or bumps the springs provides pressure to squeeze the packs together. For protection from short circuits each battery is connected in the pack by a fusible link. If a short circuit occurs, these links will heat up and cause an open circuit stopping the current from flowing.

To protect the system from faults a ground fault indicator (GFI) is used. The GFI interrupts the system if any faults occur on it. The GFI will shut down the snowmobile in the case of a fault by interrupting the auxiliary power system, which opens the contactor in the motor controller. The GFI will interrupt the system if the high voltage comes into contact with the chassis of the snowmobile. In the 2009 design only the main power system was interrupted by the GFI. For the 2010-2011 design the auxiliary power system is interrupted to improve the safety and reliability of the snowmobile, by allowing the motor controller a proper shutdown.

Eliminating the need for gasoline offsets some of the cost for the batteries when compared to an internal combustion engine. Gasoline, however, is still significantly cheaper. Over a 2000 cycle lifetime the battery system has the capability of providing approximately

13.58 MWh of energy. Using the U.S average rate for electricity of 9.83 cents/kWh [7], this adds an additional cost of 1,335 dollars. Including the cost of the batteries, motor, and parts needed for the electric snowmobile, the estimated Manufacturer's Suggested Retail Price (MSRP) is 19,972 dollars. The MSRP plus estimated costs for electricity put the emissions-free snowmobile at \$21,308. The overall efficiency of the system is approximately 90% when losses from the motor controller and motor are taken into consideration. Taking into account this efficiency, the overall energy supplied by the electrical system is approximately 12.2 MWh.

A gallon of gasoline typically has approximately 33.2kWh [9]. Gasoline internal combustion engines can have efficiencies of up to approximately 30%, therefore effectively producing 9.96 kWh/gal. To supply the same amount of energy as the electrical system 1,225 gallons of gasoline are needed. The current cost of gasoline in 2011 is \$3.189 per gallon [7]. The overall cost of gasoline to supply this energy is \$3,907; adding the MSRP of \$6,199 for the snowmobile on the manufacturer's website [11] gives an expected cost of \$10,106.

Comparing the price of the two snowmobiles, the IC vehicle is \$11,202 less than the electric. This was not surprising for new technology. The electric snowmobile is not a common vehicle, so certain parts, such as the motor controller, are going to cost more money since they cannot be bought in bulk. Also, batteries have been greatly improving through the years, and although the right batteries for price and energy were chosen this year, as time goes on there will be cheaper and more effective ways to store the energy needed. The increase in price guarantees that test results will be more accurate, and spending the extra money now ensures a cleaner environment for the future.

AUXILIARY POWER SYSTEM – The 12V system is powered by identical cells from K2 Energy as in the main power system. It consists of 4 packs in series to provide the needed 12V with each pack containing 4 cells in parallel. These were used as opposed to NiMH batteries in the 2009 design. The batteries are fused in the same manner at the high voltage pack, and can be charged at the same time as the high voltage system with a small 12V charger. While a DC-DC converter to replace this system would be ideal, the added cost and complication are not a worthwhile investment for the design at this time. In future designs, the goal will be to find a cost effective DC-DC converter to replace the 12V battery so only the high voltage batteries need to be charged.

The 12V system has also been updated to allow for easier maintenance compared to the 2009 design. The location of the 12 volt battery cells has been changed from their position below the seat. Instead they are located under the hood. The wiring for this system is also more organized than the previous years. Shown are the multiple accessories for the snowmobile that are powered by this system, such as the GFI and headlights. An improvement made to this system to improve its efficiency is LED lights, which are used as opposed to the stock lights.

This circuit also triggers the ignition of the snowmobile. When turned on it supplies power to engage the motor controller. If everything is operating correctly, such as the tether being connected, or the GFI being ok, the entire system is turned on.

BATTERY MANAGEMENT SYSTEM

Definitions:

Pack: 17 batteries in parallel. These act as one battery at 3.2V, but with a much higher energy capacity and available output current.

Bank: BMS grouping of battery packs. 6-7 packs consist of one bank for the BMS to manage, and there are 7 banks.

High Voltage Battery: 48 packs wired in series.

Using 816 batteries presented a tremendous challenge. All of the batteries were of the same chemistry, but no two batteries are identical. Some discharge faster than others. If all of the batteries are not discharging the same amount of power to the snowmobile, it creates a dangerous situation for the batteries as a whole. For instance if one pack was to drop below the 2.5V lowest rated discharge of the batteries; the manufacturer states there could be possible damage to the cells, probably causing a soft short. This would mean the snowmobile would not be running as efficiently as possible, as the batteries would be self-discharging more than undamaged cells. To solve this problem, the 2010-2011 design uses a battery management system, Lithiumate, manufactured by the company Elithion.

The batteries are balanced in their 48 different packs. The packs are arranged with two main boxes, located under the seat and on the rider's left side of the front of the snowmobile. In these boxes are a combined total of seven banks. Six of these banks will contain seven battery packs, while the other one has only six packs. The batteries wired in parallel balance each other naturally. However, the 48 packs of batteries are wired in series to reach maximum voltage, so each pack is measured individually. The BMS is capable of balancing up to 255 packs at once. The 48 packs used are well within this capacity.

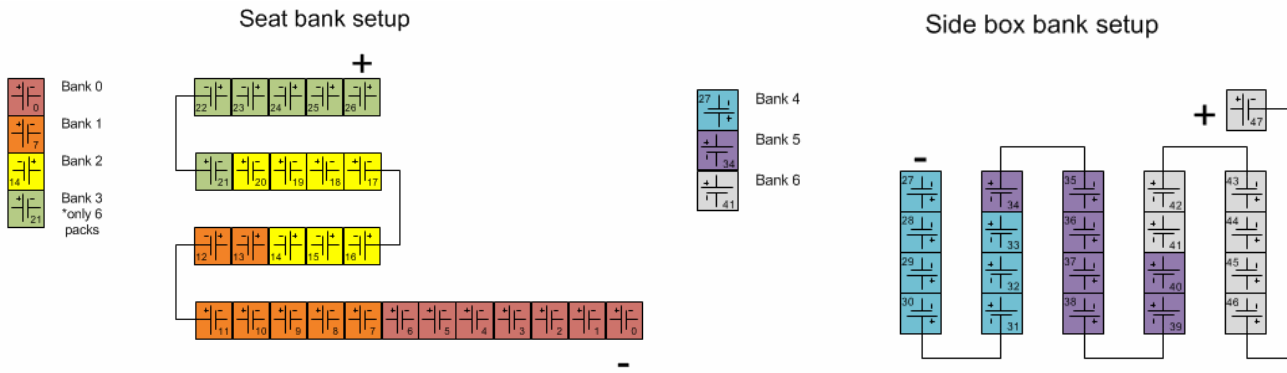

Figure 4 - BMS Bank Setup in Snowmobile

The BMS works by comparing the different packs that are connected. Any pack with a voltage higher than the rest has its charge balanced through passive dissipation of the excess energy. It drains a pack if the voltage is 0.25 V higher than the other packs. The BMS has a \pm of 10mVDC accuracy for sensing the voltages. It can also sense voltages within the range of 2.09 to 4.54 VDC. This is perfect for our application since the packs will never reach higher than 3.65V Volts and the batteries should not be discharged below 2.5V to avoid damaging the cells. The operating voltage of the battery packs is well within the limit of the BMS.

Another important feature that this BMS is capable of is reading the temperature of each individual pack. The BMS is rated for temperatures between -40 and +80 °C and has a temperature sensing accuracy of \pm 2°C. As well as temperature it can measure the current, as low as 5 Amps if needed, but more importantly up to 600 Amps. A pack which contains 17 batteries in parallel, each cell with a max current of 20 Amps, can reach up to 714A. is the motor controller settings keep the batteries from outputting more than 250A making the current well within the range of the sensor.

This BMS also provides a way to output certain values onto a display. This is installed on the main panels of the snowmobile to be easily visible for the user. It contains a 10 LED State of Charge (SOC) display, with five separate status LEDs. The 10 main LEDs light up based on the percentage of battery power. For example if all 10 LEDs are lit up, then the Snowmobile is at 100 % power. If only 3 are lit up it contains only 30% and so on. As soon as all of the LEDs turn off, the snowmobile is out of power and will need to be recharged again.

The five status displays are color coordinated, with each separate color pertaining to a different state. Looking at Figure 4, going from bottom to top the colors are: blue, green, yellow, amber, and red. The different colors signify:

- Blue – Battery is charging, connected to the power system
- Green – Enabled, Contactors are on (not used)
- Yellow – Ignition is engaged
- Amber – Current is being limited
- Red – A fault has occurred, for instance if you tried operating the snowmobile while still charging

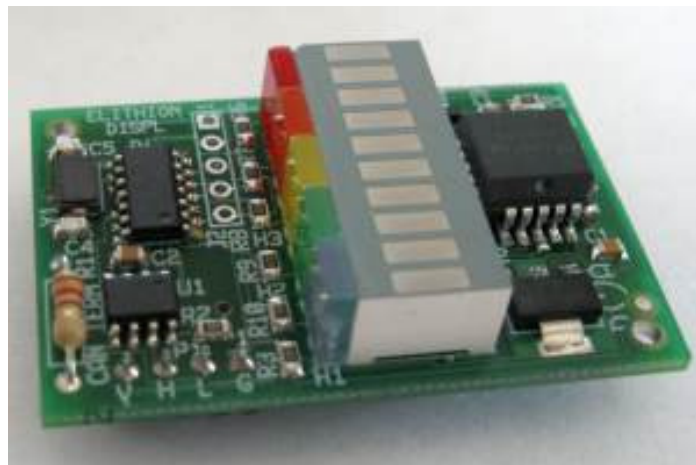

Figure 5 - SOC Display [6]

The BMS boards are connected to each separate bank which sends data back to the BMS controller. This data can then communicate through a serial port and controller area network (CAN) bus. The serial port (DE-9D-sub) is used for programming and communicating with the user through a computer. The CAN bus, for our application, is used to send data to the SOC display.

CHARGING

There are three prominent considerations in designing a battery charger: efficiency, charge time, and maintaining battery integrity. In an effort to increase the efficiency of the charger, non-resistive control techniques are implemented. Transformers and reactors are used to regulate voltage and current, performing a function similar to switched power supplies, but using a standard 60Hz voltage source to reduce complexity.

There is a trade-off between charge time and battery health. Pushing more current into the battery pack charges it faster, which is convenient, but may compromise the integrity of the battery pack. Lithium ion cells require two charge stages, a constant current stage that persists until the cell reaches maximum voltage, followed by a constant voltage stage that persists until current flow drops below a certain value recommended by the cell manufacturer. Lithium batteries are readily damaged by over charging, so it is important to accurately terminate charge current. An isolation transformer installed for safety supplies 120V to the circuit.



Figure 6 - Charger for 2011 Electric Snowmobile

A maximum safe charge current of 10A was chosen for the snowmobile, which provides a reasonable charge time without potentially degrading the batteries. Current limiting is performed by a saturable reactor connected in series between the AC input and a bridge rectifier that provides a DC voltage directly to the batteries. A low voltage DC control circuit provides saturating current that is inversely proportional to a feedback signal from a current transducer that measures the DC current flowing into the battery pack, thereby regulating the current. The constant voltage stage is achieved by a feedback signal from an isolating voltage sensor. This is connected across the output terminals of the charger. The circuit operates as a linear regulator in this mode. The BMS is connected to a relay, which it uses to terminate then charging cycle.

DRIVE SYSTEM

The drive system is powered by the main 57kW DC battery system. Battery Current enters a motor controller which converts the DC battery power to AC power. It is then passed onto the AC motor. The motor translates the power from the motor controller into rotational movement that turns the sprockets that make up the belt driven system.

MOTOR - The motor is a brushless, 3-phase AC motor from Solectria, seen in Figure 6, capable of a peak efficiency of 92%. This motor has a continuous power rating of 16 kW and a peak power of 37kW. Translated into horsepower, this particular AC motor provides continuous power of 21.45hp and a peak power of 49.60hp. The motor speed ranges from 0-10,000RPM, with a nominal speed of 4,000RPM. Also the maximum power is generated at 4,000RPM [8].

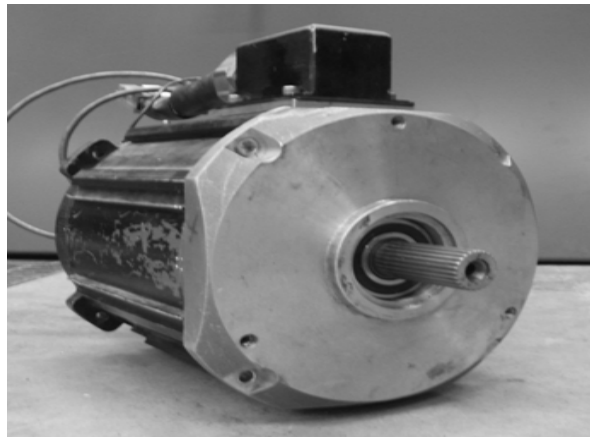

Figure 7 - Photo of Solectria AC21-A motor

MOTOR CONTROLLER – The Azure Dynamics DMOC445 was selected and programmed to control the Solectria AC21-A motor. The DMOC, as seen in Figure 7 weighs in at 14.7kg and operates at a nominal voltage of 144V. It produces a peak power of 78kW, continuous power of 38kW and is 96%-98% efficient. This controller was chosen to provide the motor with more power due to limitations of the UMOC425T used in the 2007 and 2008 designs. In choosing the DMOC445, the snowmobile shed 3.5kg due to its lighter composition when compared with the previous controller. This controller operated successfully in the 2009 competition and has continued to be used.



Figure 8 - Azure Dynamics DMOC445 motor controller

DRIVE TRAIN SELECTION – When exploring drive train options, three different types were examined as seen in Table 4. One of the design goals involves minimizing noise emissions: this immediately eliminated the chain drive which was 20 dB louder than the options of the belt drive and CVT.

Table 4: Drive train Comparison Chart

Drive Type	Life Span (miles)	Noise (dB)	Lubrication	Gear Ratios
Belt	60,000	60	None required	One (fixed)
Chain	60,000	80	Oil Bath	One (fixed)
CVT	3,000	60	None required	Infinite

Continuously Variable Transmissions, (CVTs), are used in a lot of vehicle drive systems to provide more torque at lower speeds. Due to the fact that electric motors provide instant torque at low speeds, a CVT is unnecessary in an electric vehicle. The drive train that is included involves a drive system which is belt driven, due to its ease of implementation, low cost, long life span, and low noise emissions. The specifications of the system were designed to take advantage of speed, torque, and efficiencies that the motor had to offer, as determined from Figures 9 & 10. Torque is a function of speed, so by manipulating the gear ratio to increase or decrease speed allows the torque output to be modified.

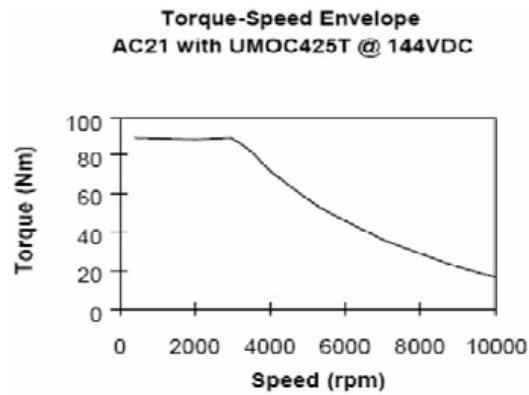

Figure 9 - Motor Torque-Speed Envelope

The 2008 snowmobile design sported an overall gear ratio of 5:1. This drive system outputs a max torque of 450Nm. At competition in 2008, during the Draw Bar Pull, the snowmobile lost traction very early into the test, indicating there was too much instant torque. The track was overcoming the maximum static friction between the track and snow. With this limitation from 2008 in mind, the 2009 drive system was designed with a gear ratio of 2.5:1. This ratio output a maximum 225Nm of torque and proved to be effective.

Optimizing the system again for 2010 the overall gear ratio was adjusted to 4:1, increasing the snowmobile's torque. With this ratio the drive system outputs a total torque of 360Nm. The extra torque was chosen to increase performance in the new Load + Speed + Handling event. This design decreases the speed and increases the torque from the 2009 design, and helped the team win the drawbar pull event in 2010, pulling 737lbs before losing traction.

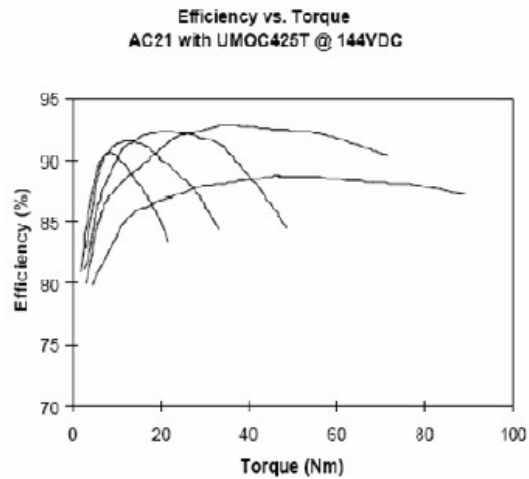

Figure 10 - Motor efficiency graph

The design of the drive system presented some challenges. The correct sprocket sizes had to be selected to provide the appropriate speed reduction and handle the torques present in the system while also fitting within the space restrictions of the chassis. As a result of the restrictions, the desired ratio was achieved in two stages. The system provides the overall gear ratio of 4:1. With the help of the Gates design manual, appropriate sprocket diameters and widths were selected. The sprockets were custom made by Motion Systems, according to the specifications. A 21 mm wide belt connects the motor's sprocket to the first stage sprockets located on a nearby shaft. Located on the same shaft is the second stage sprocket, which runs to the driveshaft using a 36 mm wide belt. Gates-Polychain belts are used, which can withstand the speed and range of the snowmobile while still limiting noise emissions.

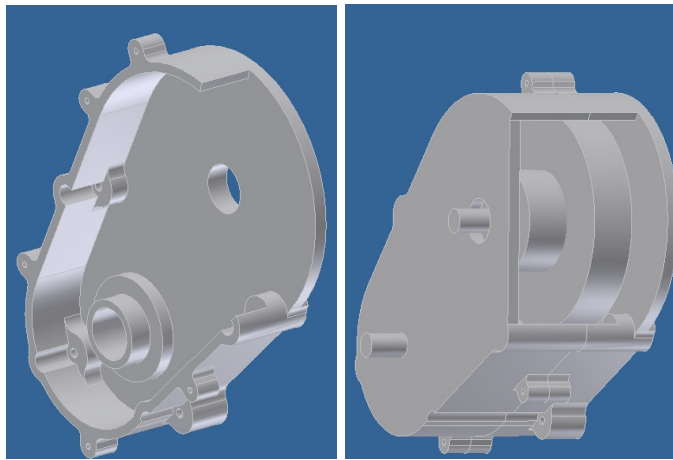

Figure 11 - (Left) Bottom outside half of Belt Case. (Right) Completed Belt Case

The specifications of the completed pulley case shown in Figure 11 are:

- ❖ Motor pulley: 1.2"Wx3.6"Dia, 33 Teeth
- ❖ Secondary: 1.75"Wx9"Dia, 90 Teeth
- ❖ Pulley on secondary shaft: 1.86"Wx4.2"Dia, 38 Teeth
- ❖ Drive Pulley: 1.86"Wx6"Dia, 56 Teeth

Another large change made to the snowmobile involved the motor. To clear more space in the front area, the chain case is removed. The motor is also rotated so that the motor's pulley and driveshaft are located adjacent to one other. It is mounted to two yolks, which pivot about a shaft. This allows for easy adjustment and tension by turning a threaded lead screw. The lead screw is fixed to the tunnel at one end and to the yolk at the other, adjusting the lead screw causes the motor to pivot.

Additionally the motor is mounted lower, providing the snowmobile a lower center of gravity. A lower center of gravity improves the handling of the snowmobile. The approximate weight for this system is 50lbs. The case for the pulleys was re-designed and then made in-house out of 6061 Aluminum. Although heavier, this system will be much quieter than traditional chain drive systems.

The overall drive system is expected to provide a top speed estimated at 60MPH, without any load or resistance.

TRACTION

In accordance with the design goal of a light weight snowmobile and less sound emission, the team looked for ways to improve the traction components while attempting to meet design goals.

SKIS – The stock Polaris skis are not one piece and are bolted at the together at the top of the ski. This led to the assumption that the flexion of the ski created noise at the bolted connection. In order to reduce possible noise caused by the design of the ski, the team replaced the stock ski with a touring ski from Camoplast. Camoplast's touring ski is blow-molded creating a single piece ski that is comparable in dimensions to the stock Polaris ski and offers a reduced weight of 2.05kg.

SUSPENSION – The 2006 Polaris 600RR is fitted with Walker Evans race shocks that help cushion the added weight of batteries as well as absorb trail shock during riding. Electric motors are relatively quiet when compared to internal combustion engines, so most of the noise emitted can be attributed to the track. In order to make the rear suspension as efficient and quiet as possible, a new rear shock was attached to the skid frame as well as new block wheel mounts to reduce side to side movement of the bogey wheels. These changes will help negate unnecessary movement by component parts and help reduce noise emissions.

SKID FRAME – In order to further reduce weight, the stock skid frame was replaced with a ZX² composite suspension. Produced by AD Boivin, this skid frame is adjustable and reduces the weight of the snowmobile by 12lbs, or 5.44kg. While the additional cost is fairly high, the weight reduction improves the range of the snowmobile.

TRACK – A Camoplast Ripsaw track comes standard on the 2006 Polaris 600RR. In order to reduce the opportunity for slippage in the draw bar pull, the team switched to Camoplast's Cobra track which offers a slightly longer lug length at an additional weight of one kilogram. The track has also been studded to improve traction for pulling a heavy load.

HANDLING

In order to maintain a center of gravity close to that of a stock snowmobile, the team has organized the battery system in a way to balance the weight. The bulk of the batteries are arranged inside the old gas tank over the front portion of the track. This keeps the overall weight situated over the skis and over the front of the track while keeping the center of gravity low to avoid snowmobile roll-overs. The center of gravity was also lowered by remounting the motor in a lower position, compared to the 2009 design. Another improvement to the 2009 design is the weight underneath the hood of the snow mobile is balanced. Located in the front right area under the hood is the pulley system from the motor used to drive the track. Balancing this weight is the remainder of the batteries located in the front left area under the hood. The suspension includes Walker Evans racing shocks that help cushion rough trails, which help improve impact absorption and prevent the rider from getting the brunt of the shock. The stock skid frame was replaced with an AD Boivon ZX2 suspension base, which is adjustable, allowing the rider to tune the snowmobile to his or her needs. The Camoplast Cobra track that replaced the Camoplast Ripsaw also helps to improve handling by providing better grip.

NOISE EMISSIONS

Due to the natural low noise emissions of electric motors, it is generally difficult to distinguish one electric snowmobile as being quieter than another. Making slight, inexpensive changes to a snowmobile will be important in trying to reduce noise emissions.

There are two main sources that contribute to noise emissions. One source is the motor and the second is the track. The motor is noticeably quieter when compared to the track, but the drive system must be covered to prevent injury in the case of drive failure or catastrophe. This offered an opportunity to reduce noise emitted from the motor. The track noise can be reduced through the use of a track skirt, but this option is not visually pleasing. Rather than adding a track skirt, the team decided to make the track as efficient as possible by replacing old worn parts such as the slide rails and block wheel mounts to prevent undesired movement and noise. Noise dampening and use of quiet drive components resulted in 63 dB of noise as the snowmobile drives by, which is as quiet as a library conversation. The benefits of a quiet design include being able to converse while two or more electric snowmobiles are running (a drawback of IC snowmobiles during necessary communication between riders), not disturbing wildlife, and improving the public acceptance of snowmobile trails routed close to private homes.

RANGE

Maximizing the range of the snowmobile requires its operation to be as efficient as possible. This includes the combined losses from the main battery system to the motor, moving components due to friction, and the weight of the snowmobile. The BMS equalizes the main battery system to ensure the most efficient discharge. The more efficient motor controller added in the 2009 design also improves the overall electrical system. Simplification of the drive train and replacement of bearings, slide rails, skis, skags, and rear suspension seek to reduce friction of moving parts. Reduction of friction within moving parts requires less energy consumption to overcome internal frictional forces making it easier to propel the snowmobile. Finally a lighter weight vehicle requires less energy to move. By incorporating lighter parts such as the skis, sprockets, motor controller, and the composite skid frame, the snowmobile requires less energy for overcoming both starting friction and dynamic friction. Energy consumption is inversely related to range, so lower energy consumption means further range. Based upon the overall design of 2009, compared to this year's electric snowmobile, the range is approximately equivalent. Compared to the 2009 design there is a similar weight and energy capacity. With those two in mind, it can be estimated that the snowmobile will perform approximately the same as in 2009, and therefore travel 15-20 miles per charge in good conditions.

TOWING CAPACITY

Towing capacity is important for an electric snowmobile, as its main use is for transporting goods and equipment in Greenland for the NSF. Not only must the snowmobile be able to pull a heavy load, but must have the battery capacity to pull that load for the required distance.

Towing capacity features many challenges such as finding the right balance between torque and speed along with determining the right amount of traction needed. One solution is to improve traction by adding studs to the track, and the added traction is worth the added weight and noise emissions. The system used in the 2009 design pulled a maximum of 492.8 lbs before the snowmobile lost traction. It was a significant improvement from 382.1 lbs in the 2008 design. The 2010-2011 design uses the same additional lug length on the track, with studs for added traction, and some unnecessary torque has been exchanged for speed with a different gear ratio. These changes improved towing capacity in the 2009 competition by 100 lbs compared to previous years. In 2010, the improvements earned the team the draw bar pull award, with the snowmobile towing 737lbs. In Greenland, the snowmobile was used

to tow a variety of materials, including gas tanks, research equipment, and other heavy gear that would normally be dragged on sleds pulled by the researchers. Figure 12 shows the snowmobile being used by a researcher in Greenland.



Figure 12 - Electric Snowmobile Towing Research Equipment in Greenland (Photo Courtesy of Scott Keefe)

COST

Although cost is an important factor, it is not a priority in this design. The cost of the sled is a small percentage of possible points that can be earned in competition as it is not of high importance for its use in Greenland. Points lost by having an expensive snowmobile are easily made up by the improved performance in other areas of competition. This performance is also a necessity for its intended application as a zero emissions transport vehicle in Greenland. With the current technology available an electric snowmobile that can operate comparable to that of an IC comes with a cost. The largest reduction in cost pursued in 2010 was to change our battery chemistry. This switch alone from Lithium Polymer to Lithium Iron Phosphate led to a cost reduction of \$3,300. However this lower cost was offset by increased prices of other components of the snowmobile, such as the BMS and new skid frame.

CONCLUSION

This year's design has addressed many of our goals based on previous experience at competition. The Lithium Iron Phosphate battery chemistry effectively provides a safe alternate to the Lithium Polymer chemistry used in previous years. The chemistry supplies a comparable amount of power and energy to the snowmobile. The battery packs are also located in positions such that the weight distribution within the sled is kept even to provide better handling.

The Elithion BMS is an important investment for the snowmobile in the years to come. It effectively balances the battery system and keeps the snowmobile safe. The BMS also provides sensors that can be used to monitor the status of the system. Along with these improvements to the main power system the auxiliary power system was improved as well. It is more organized within the snowmobile, and important pieces of it have been moved to allow for easier maintenance.

The 2010-2011 motor mount and pulley system used simplifies and improves the drive train. It requires less space and the 2010-2011 position improves the snowmobile's handling with a better weight distribution. The gear ratio of this system also increases the torque to the track for the events that tests its ability to pull a load. Additionally, the new composite skid frame will provide good performance while reducing weight.

The end result is a snowmobile which doesn't appear electric from the outside when compared to an IC vehicle. Operation is similar to that of an IC snowmobile. However, designing a safe electric snowmobile that operates comparably to an IC engine comes with a cost. Batteries with high energy densities, better motors and controllers, and systems to ensure the safety of the batteries prove to be a large investment. Overall the team has met challenges and expectations head on and has created a zero emissions snowmobile that can be effectively used to transport people and equipment in pristine areas.

ACKNOWLEDGEMENTS

The Clarkson University Electric Knights would like to extend a great deal of thanks to ESD Systems, Honeywell and Salisbury High Voltage Protection, Gates Corporation, Cadsoft Corporation, Advanced Circuits, Camoplast Corporation, Anderson Power Products, Vicor Corporation, Omega Engineering, EV Components, the Clarkson University ECE Department, and Woody's International for their generous donations. Without the help of these companies, many of our goals could not have been met. We also thank Professor Paul McGrath, Professor Thomas Ortmeyer, Professor Joseph Potvin, and especially Lou Loggi for assisting us with their expertise.

REFERENCES

- [1] Nexergy, "Energy Density Comparison".
Accessed online 11 Feb 2010
<http://www.nexergy.com/battery-density.htm>
- [2] Nexergy, "Battery Chemistry Selector".
Accessed online 11 Feb 2010
<http://www.nexergy.com/battery-chemistries.htm>
- [3] Elithion, "K2 Energy LFP26650EV Energy Cell"
Accessed online 16 Feb 2010
<http://liionbms.com/pdf/k2/LFP26650EV.pdf>
- [4] Elithion, "K2 Energy LFP26650P Power Cell"
Accessed online 16 Feb 2010
<http://liionbms.com/pdf/k2/LFP26650P.pdf>
- [5] SAE International, "2011 SAE Clean Snowmobile Challenge Rules"
Accessed online 28 Jan 2011
<http://students.sae.org/competitions/snowmobile/rules/rules.pdf>
- [6] Elithion, "Lithiumate Manual"
Accessed online 16 Feb 2010
<http://lithiumate.elithion.com/php/index.php>
- [7] U.S. Energy Information Administration, U.S. Retail Gasoline Prices
Accessed online 24 Feb 2011
http://www.eia.doe.gov/oil_gas/petroleum/data_publications/wrgp/mogas_home_page.html
- [8] Solectria Corporation. (2000). Solectria Motors.
Solectria.
<http://www.solren.com/downloads/ac21a.pdf>
- [9] Golnik, Arthur. (2003) "Energy Density of Gasoline". Physics Factbook.
Accessed online 22 Feb 2010 <http://hypertextbook.com/facts/2003/ArthurGolnik.shtml>
- [10] Hodge, James D. Ph.D, Chief Technical Officer
Email Message to Leif R. Amber 2-8-2010
K2 Energy Solutions, Inc.
- [11] Polaris. (2008). 08Performance // 600RR.
Snowmobiles: Performance: 600RR: Overview
Accessed online 24 Feb 2010
<http://www.polarisindustries.com/en-us/snowmobiles/Performance/600RR/Pages/Specifications.aspx>
- [12] HobbyKing.com Lipo Finder
Accessed on 2/25/2011
<http://www.hobbycity.com>